



Forged Vessel Connections

an AMERI-FORGE GROUP company

MAILING ADDRESS:

P. O. Box 38421
Houston, TX 77238-8421

**MAIN PLANT, DOMESTIC
AND INTERNATIONAL**

SALES OFFICES:

2525 DeSoto St.
Houston, TX 77091

1-800-231-2701

1-713-688-9705

FAX: 1-713-688-7954

FAX: 1-713-688-7518

FAX: 1-713-688-1846

WEB PAGE:

<http://www.fvc.cc>

E-MAIL:

sales@fvc.cc

CANADA OPERATIONS:

**WESTERN CANADIAN
SALES & DISTRIBUTION**

7410A-5 Street S.E.
Calgary, Alberta T2H-2L9

1-800-382-3490

1-403-255-9011

FAX: 1-403-255-7239

E-MAIL:

wcanada@fvc.cc

Pressure Vessel Connections

- Long Welding Necks • Heavy Barrel Type HB Necks
- Variable Body Type V₁, V₂, V₃ Necks • Full Body Type F Necks
- Studding Outlets • Custom Products • Rough Forgings
- Insert Type "Q" Nozzles

Table of Contents

Introduction to FVC	4
FVC Standard and Variable Body Connections	7
Introduction to Seamless Construction	8
LWN, HB, F, V ₁ , V ₂ , and V ₃ :	
Class 150	12
Class 300	16
Class 400	20
Class 600	24
Class 900	28
Class 1500	32
Class 2500	36
General Notes for FVC Connections	40
FVC Studding Outlets	41
Introduction to Studding Outlets	42
Class 150	44
Class 300	45
Class 600	46
Class 900	47
Class 1500	48
Class 2500	49
General Notes for FVC Studding Outlets	50
FVC Custom Products	53
Introduction to FVC Custom Product Capabilities	54
Technical Section	57
Technical Table of Contents	58
Warranty and Terms	80



Custom Products

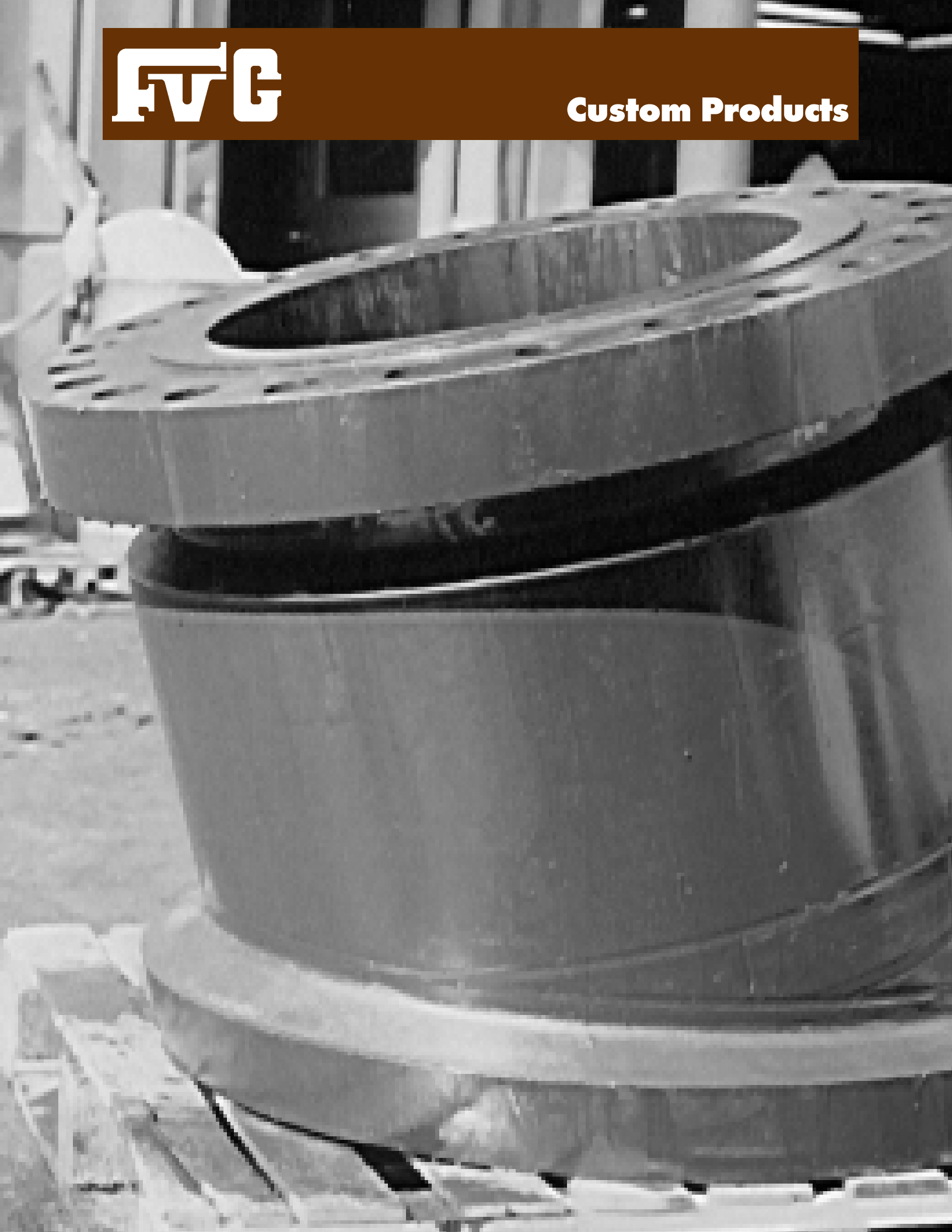



Custom Products

How often have you called a flange manufacturer or a local machine shop to order a special flanged nozzle connection and were told “Well, that’ll be six to eight weeks before I can get a forging,” when you needed it yesterday? FVC realizes that service is a vital part of this business, therefore, we have developed extensive in-house forging capabilities. Many times FVC has a suitable forging in stock or is able to manufacture your rush order by using a die already designated for use in the current forging schedule. FVC’s in-house capabilities and desire to service our customers provides you with a single

source manufacturer to solve your delivery dilemma.

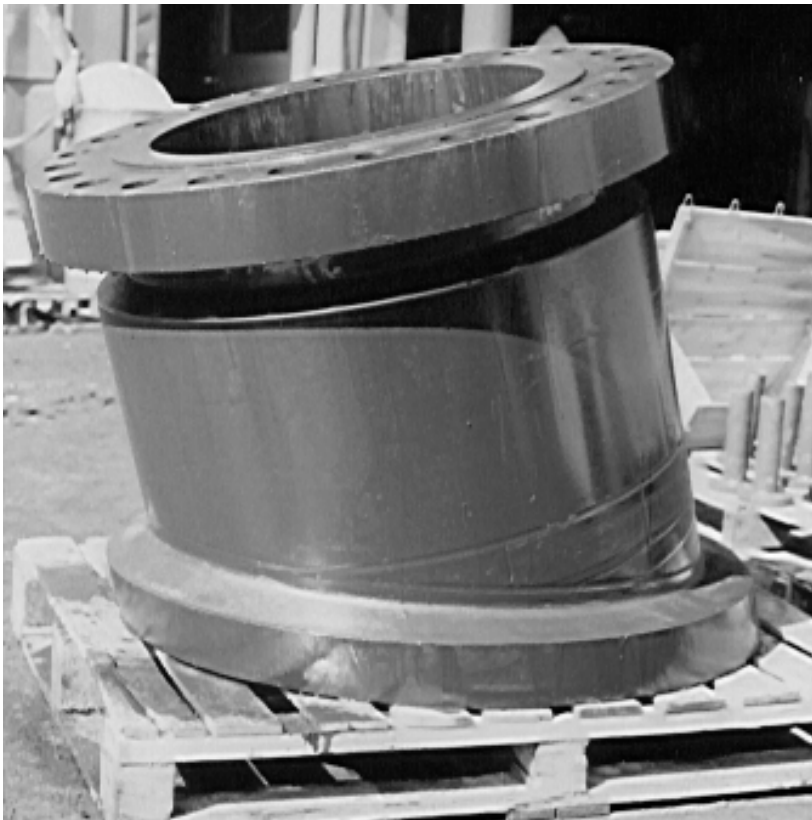

ABOVE: FVC Insert Type “Q” Nozzle for hillside installation in a large vessel.

FVC manufacturing capabilities are not limited to ASME pressure vessel nozzles. Many custom products have been forged and machined at Forged Vessel Connections, Inc., a few of which can be seen on the pages of this section. FVC welcomes the opportunity to assist customers with forging or machining estimates of special products. Given the opportunity during the early design stages of a project, FVC personnel will provide assistance on a no-charge basis whenever our expertise is applicable in solving your problems.

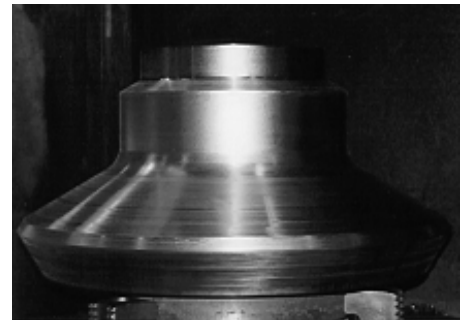

ABOVE: Special Conical Reducer fitting for reactors. BELOW: Special tooling to produce forged bolts with induction heating.



Custom Products



Custom Design of Bolted Flanges and Self-Reinforced Connections

In spite of FVC's concentrated effort to develop standard ASME flanged connections to suit your vessel requirements, there are still applications for custom designed nozzles. Custom flange design can help eliminate unnecessary material and bolting. The savings become most apparent when the ASME size and pressure class is 16"-900# or larger. Significant savings can be realized for smaller sizes, especially when alloy materials are required, FVC can provide custom design of bolted flanges, matching WNFs, manway assemblies, reducing slip-ons and/or blindflanges. The following information is required to develop an economical custom flange:

1. APPLICABLE DESIGN CODE
2. FLANGE AND BOLTING MATERIAL SPECIFICATION
3. GASKET STYLE, MATERIAL, AND THICKNESS
4. MINIMUM NECK THICKNESS
5. DETAILS OF MATING FLANGE (NUMBER OF BOLTS, BOLT CIRCLE DIAMETER)
6. NOZZLE BORE DIAMETER
7. DESIGN PRESSURE, TEMPERATURE, AND CORROSION ALLOWANCE
8. STYLE OF FLANGE -- TAPERED HUB, LOOSE RING OR A STRAIGHT HUB, WITH OR WITHOUT NUT RELIEF

FVC can provide complete design of special self-reinforced connections with all of the advantages of seamless construction. When large quantities of the same size are required, special designs and dies can be developed to provide more exacting reinforcing wall thicknesses. The following information is required to develop an economical special self-reinforced nozzle:

1. APPLICABLE DESIGN CODE
2. MATERIAL SPECIFICATIONS FOR BOTH VESSEL AND NOZZLE
3. VESSEL THICKNESS AT NOZZLE
4. VESSEL I.D. AND NOZZLE BORE
5. LOCATION OF NOZZLE IN VESSEL (SHELL, HEAD, OR CONE)
6. INTERNAL PROJECTION ALLOWED AND EXTERNAL PROJECTION
7. DESIGN PRESSURE, TEMPERATURE, AND CORROSION ALLOWANCE
8. STYLE AND RATING OF FLANGE OR PIPE O.D. FOR "BUTT WELD" CONNECTION



ABOVE: Studding outlets with RTJ facing. BELOW: Blind Bottom stub for economical hydrotesting (eliminates the welding of plugs or blinds).





Custom Products

RIGHT ABOVE: Special connection with ASME flange on one end and slip fitting for welding to pipe on the other end.

RIGHT BELOW: 14" x 150# one-piece transition nozzle. Standard ASME flange to oval heat exchanger tubing.

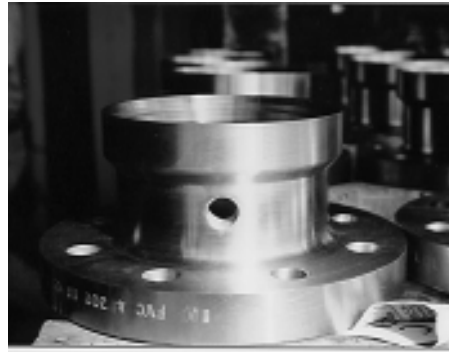

Custom Forged Production Parts

FVC is capable of forging close to the contour of the finished part thereby eliminating costly machining time and scrap material. New dies can be developed or dies from FVC's large inventory of tooling can be modified to save you tooling costs. A free estimate from FVC will assist in your economic decisions. A sketch and a summary of your specific requirements will aid FVC in developing a speedy reply.

The FVC Insert Type "Q" Attachment

When you require nozzle attachments using full penetration butt welds, similar to those shown in ASME Section VIII, Div. 1, Fig. UW16.1 (f) and Div. 2, Fig. AD-613.1, FVC is able to provide design assistance in order to minimize total installed cost. The type "Q" attachment can be provided on any style FVC connection, including studding outlets, and can be manufactured to allow a butt weld attachment for nozzles with either radial or tangential orientation. The type "Q" attachment makes weld examination easier and allows radiographs of nozzle-to-vessel welds to be interpreted more accurately.

FVC Insert Type "Q" HB nozzle and welding stub ready for contour burning of bottom radius.

Special Petroleum Manways

These nozzle neck and blind flange assemblies have been developed by end

users which provide seamless construction, a superior tongue and groove facing and a lower "weight-to-service rating" ratio than ASME flange assemblies. Several sizes and pressure ratings of these manway assemblies are manufactured and stocked by FVC. Please inquire with FVC for dimensional details, service rating, and pricing.

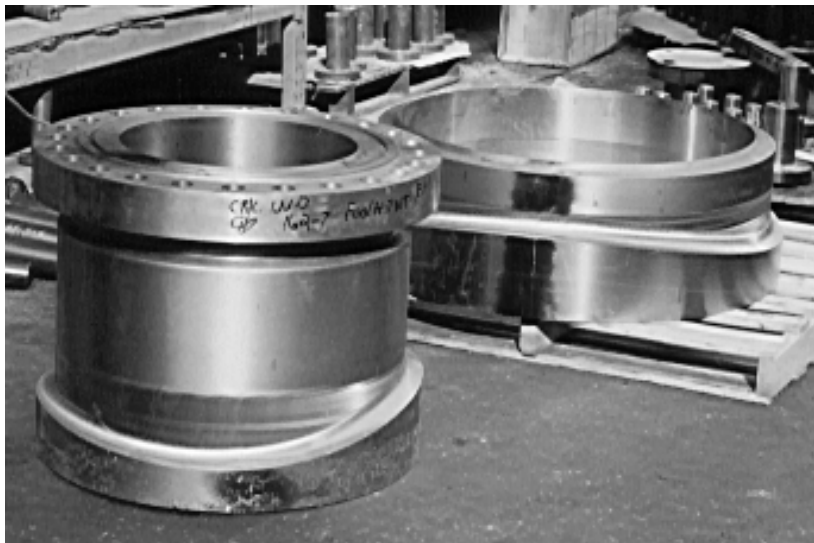

Please note that FVC reserves the right to require approved manufacturing drawings prior to execution of custom orders.



Technical Section





Technical Table of Contents

Material Specifications	59
Standard Tolerances	60-61
Standard Weld Bevel Details	61
Standard Facings and Notes	62-63
Ring Type Joint Facing Dimensions	64-65
Properties of Pipe: Dimensions and Weights	66-67
ASME Pressure-Temperature Ratings	68-72
ASME Maximum Allowable Hydrostatic Test Pressures	72
Bolting Dimensions	73
Bolting Materials	73
Useful Conversion Factors	74-75
Sweep Loss Chart	76-77
Conversion, Table, Fractions to Decimals to Millimeters	78
Weight of Circular Steel Plates	79



Material Specifications For FVC Products Chemical Composition (%)

Specification	C	Mn	P (Max)	S (Max)	Si	Ni	Cr	Mo	V (Max)	Al (Max)	Cu (Max)
SA-105* **	0.35 (Max)	0.6-1.05	0.04	0.05	0.35 (Max)	-	-	-	-	-	-
SA-182-F1	0.28 (Max)	0.6-0.9	0.045	0.045	0.15-0.35	-	-	0.44-0.65	-	-	-
SA-182-F5	0.15 (Max)	0.3-0.6	0.03	0.03	0.5 (Max)	0.5 (Max)	4.0-6.0	0.44-0.65	-	-	-
SA-182-F11	0.1-0.2	0.3-0.8	0.04	0.04	0.5-1.0	-	1.0-1.5	0.44-0.65	-	-	-
SA-182-F12	0.1-0.2	0.3-0.8	0.04	0.04	0.1-0.6	-	0.8-1.25	0.44-0.65	-	-	-
SA-182-F22	0.15 (Max)	0.3-0.6	0.04	0.04	0.5 (Max)	-	2.0-2.5	0.87-1.13	-	-	-
SA-182-F304	0.08 (Max)	2.0 (Max)	0.04	0.03	1.0 (Max)	8.0-11.0	18.0-20.0	-	-	-	-
SA-182-F304L	0.035 (Max)	2.0 (Max)	0.04	0.03	1.0 (Max)	8.0-13.0	18.0-20.0	-	-	-	-
SA-182-F316	0.08 (Max)	2.0 (Max)	0.04	0.03	1.0 (Max)	10.0-14.0	16.0-18.0	2.0-3.0	-	-	-
SA-182-F316L	0.035 (Max)	2.0 (Max)	0.04	0.03	1.0 (Max)	10.0-15.0	16.0-18.0	2.0-3.0	-	-	-
SA-182-F321	0.08 (Max)	2.0 (Max)	0.04	0.03	1.0 (Max)	9.0-12.0	17.0 (Min)	-	-	-	-
SA-350-LF1 *	0.3 (Max)	1.35 (Max)	0.035	0.04	0.15-0.3	-	-	-	-	-	-
SA-350-LF2 *	0.3 (Max)	1.35 (Max)	0.035	0.04	0.15-0.3	-	-	-	-	-	-
SA-350-LF3 *	0.2 (Max)	0.9 (Max)	0.035	0.04	0.2-0.35	3.25-3.75	-	-	-	-	-
SA-508 GR2	0.27 (Max)	0.50-1.00	0.025	0.025	0.15-0.40	0.50-1.00	0.25-0.45	0.55-0.70	0.05	-	-
SA-508 GR3	0.25 (Max)	1.20-1.50	0.025	0.025	0.15-0.40	0.40-1.00	0.25 (Max)	0.45-0.60	0.05	-	-
SA-765 GR2	0.30 (Max)	0.60-1.05	0.020	0.020	0.15-0.35	0.50 (Max)	0.40 (Max)	0.25 (Max)	0.05	0.05	0.35
SAE-4130	0.28-0.33	0.4-0.6	0.04	0.04	0.2-0.35	-	0.8-1.10	0.15-0.25	-	-	-

* FVC stocks chemistries which comply with "Sour Service" requirements (NACE).

** For each reduction of 0.01% below the specified carbon maximum (0.35%), an increase of 0.06% manganese above the specified maximum (1.05%) will be permitted up to a maximum of 1.35%.

Notes:

1. The materials listed above are typical of FVC inventory and are subject to availability.
2. Other materials can be provided based on special orders which may be subject to prior sale and quantity minimums.

ASME Material Compatibility

Forging Spec.	P.V.Q. Plate Spec.	Pipe Spec.	Fitting Spec.
SA-105 SA-350-LF1 SA-350-LF2 SA-350-LF3	SA-285, SA-515 SA-515, SA-516 SA-516 SA-203-GR D	SA-53, SA-106 SA-333-GR 6 SA-333-GR 6 SA-333-GR 3	SA-234WPB SA-420WPL6 SA-420WPL6 SA-420WPL3
SA-182-F1 SA-182-F5 SA-182-F11 SA-182-F12 SA-182-F22	SA-204 SA-387-GR 5 SA-387-GR 11 SA-387-GR 12 SA-387-GR 22	SA-335-P1 SA-335-P5 SA-335-P11 SA-335-P12 SA-335-P22	SA-234-WP1 SA-234-WP5 SA-234-WP11 SA-234-WP12 SA-234-WP22
SA-182-F304 SA-182-F304L SA-182-F316 SA-182-F316L SA-182-F321	SA-240-304 SA-240-304L SA-240-316 SA-240-316L SA-240-321	SA-312-TP304 SA-312-TP304L SA-312-TP316 SA-312-TP316L SA-312-TP321	SA-403-WP304 SA-403-WP304L SA-403-WP316 SA-403-WP316L SA-403-WP321

FVC Connection Tolerances

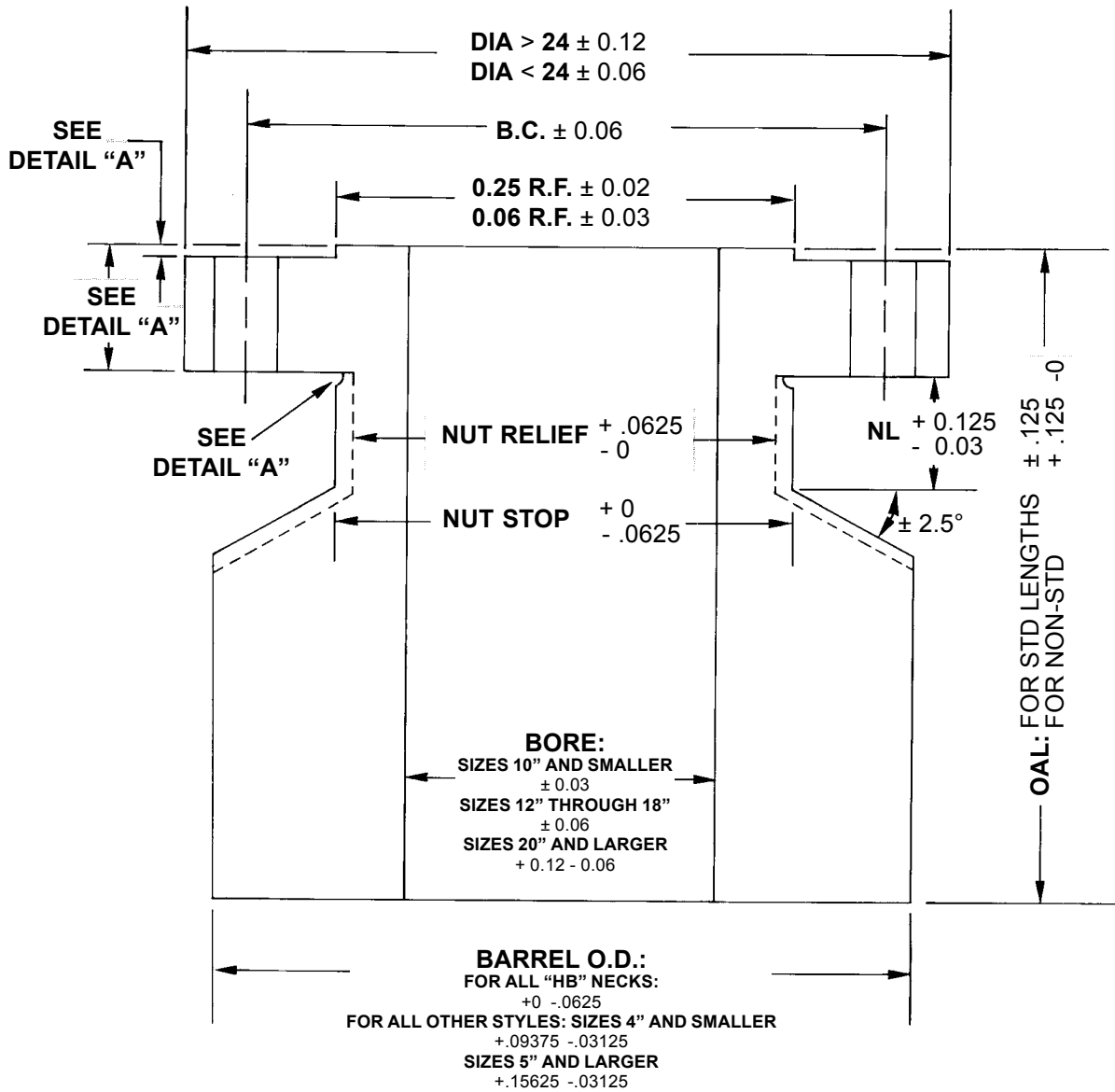

- General Notes:**
- 1) All dimensions are in inches.
 - 2) FVC connections are manufactured in accordance with the tolerances set forth by ASME B16.5.
 - 3) Tolerances may be modified to meet customer requirements when specified.

FVC Connection Tolerances

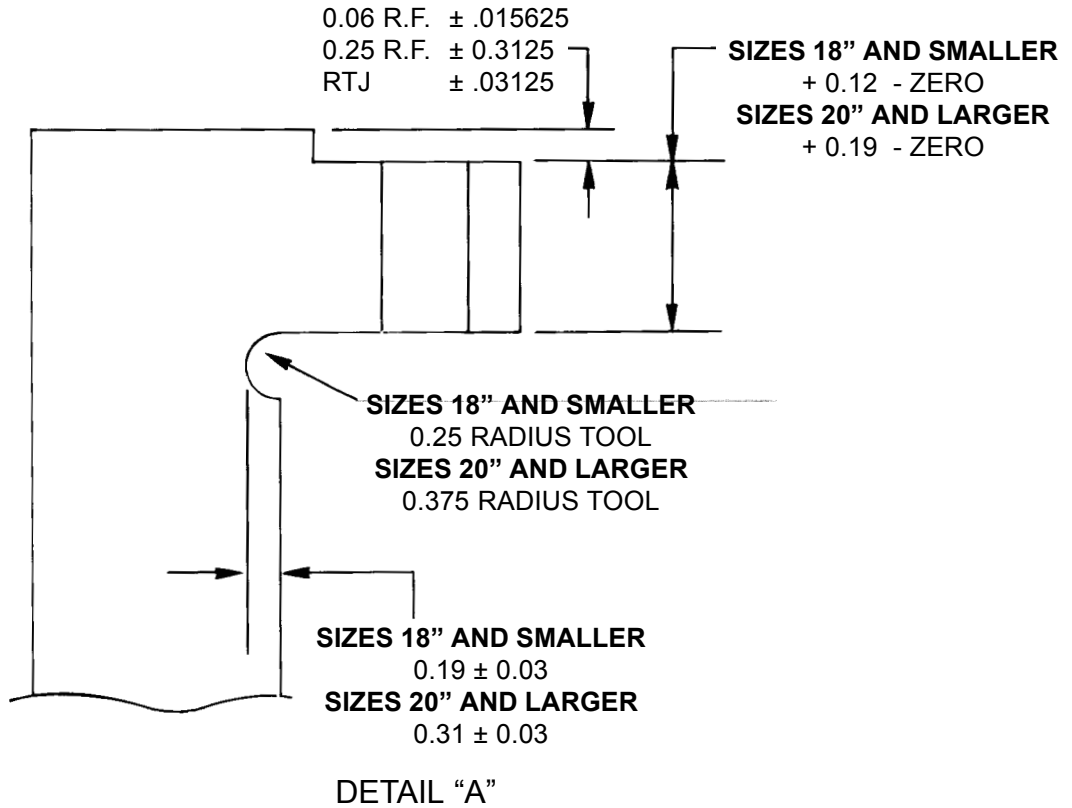

Note: Undercut dimensions and tolerances comply with ASME Section VIII Division 1, Fig 2-4

FVC Welding Bevel Details

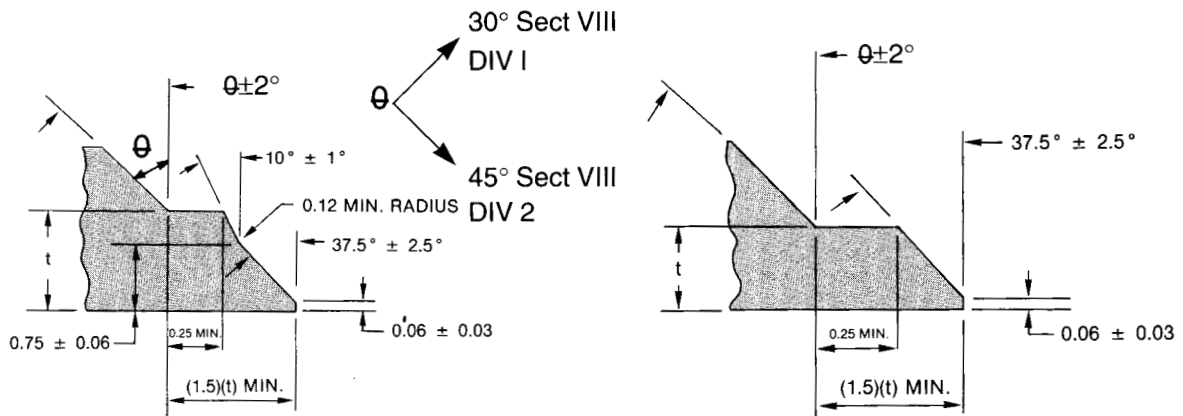

COMPOUND BEVEL ($t > 0.88$)

SINGLE BEVEL ($t \leq 0.88$)

Bevel dimension and tolerances are based on ASME B16.5. The above details will be provided unless otherwise specified. Other bevels are available upon request.



General Notes For FVC Flange Facings

FVC connections are available with numerous standard and special facings. The more popular standard facings are described on the following pages. Customers are requested to furnish details for any special facings desired.

Raised Face:

The facing height and outside diameter are specified in the standard product dimensional tables. The serrations are spiral and are in accordance with the requirements of the latest issue of ASME B16.5 and MSS-SP6.

Flat Face:

All pressure class flanges may be ordered flat faced. On 150# and 300# rated flanges, the raised face normally furnished will be removed by machining. The resulting minimum flange thickness will be 0.06 inch less than that specified as dimension "T" in the standard product dimensional tables. On flanges rated 400# and above, the raised face normally furnished will also be removed by machining. However, the resulting flange thickness will not be less than the specified dimension "T".

As an alternate, all flat face flanges may be ordered as "full-face"- "flat face". In this case, 150# and 300# rated flanges will have a resulting minimum flange thickness of no less than that specified as dimension "T". Any 400# and higher rated flanges will be provided with a minimum flange thickness of that specified as dimension "T" plus 0.25 inch.

In all cases, the entire flange surface will be finished to a roughness not exceeding 250 AARH, unless otherwise specified by the customer.

All options mentioned above are per ASME B16.5 Standards.

Rough Face:

Except as otherwise specified, no finish machining will be performed on rough forgings. No holes will be drilled. A minimum of 0.12 inch will be provided on all surfaces for customer machining. Facing heights exceeding those of a standard raised face must be indicated.

RTJ:

The table on pages 64 and 65 gives the dimensions applicable to ring type joint facings. The side walls of the gasket groove are finished to a surface roughness not exceeding 63 microinches.

Other Standard Facings:

The dimensional details of other standard facings are presented in the table on the following page.

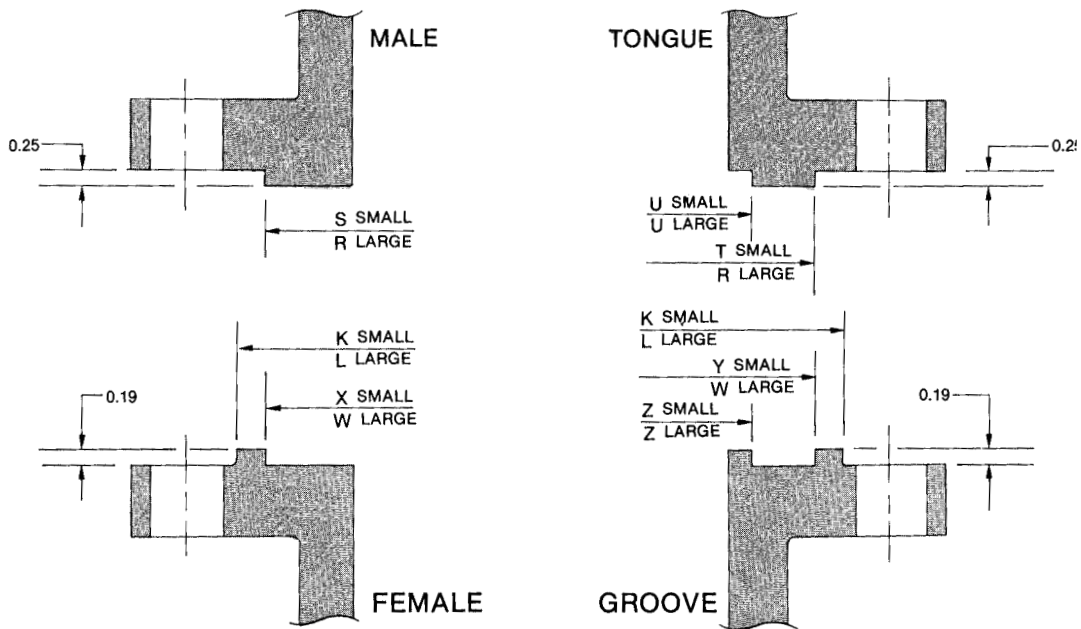

THIS TABLE LISTS THE DIMENSIONS FOR STANDARD MALE, FEMALE, TONGUE AND GROOVE FACINGS AVAILABLE ON ALL FVC CONNECTIONS.

FLG Size	R	S	T	U	W	X	Y	Z	K	L
½	1.38	0.72	1.38	1.00	1.44	0.78	1.44	0.94	1.75	1.81
¾	1.69	0.94	1.69	1.31	1.75	1.00	1.75	1.25	2.06	2.12
1	2.00	1.19	1.88	1.50	2.06	1.25	1.94	1.44	2.25	2.44
1¼	2.50	1.50	2.25	1.88	2.56	1.56	2.31	1.81	2.62	2.94
1½	2.88	1.75	2.50	2.12	2.94	1.81	2.56	2.06	2.88	3.31
2	3.62	2.25	3.25	2.88	3.69	2.31	3.31	2.81	3.62	4.06
2½	4.12	2.69	3.75	3.38	4.19	2.75	3.81	3.31	4.12	4.56
3	5.00	3.31	4.62	4.25	5.06	3.38	4.69	4.19	5.00	5.44
3½	5.50	3.81	5.12	4.75	5.56	3.88	5.19	4.69	5.50	5.94
4	6.19	4.31	5.69	5.19	6.25	4.38	5.75	5.12	6.19	6.62
5	7.31	5.38	6.81	6.31	7.38	5.44	6.88	6.25	7.31	7.75
6	8.50	6.38	8.00	7.50	8.56	6.44	8.06	7.44	8.50	8.94
8	10.62	8.38	10.00	9.38	10.69	8.44	10.06	9.31	10.62	11.06
10	12.75	10.50	12.00	11.25	12.81	10.56	12.06	11.19	12.75	13.19
12	15.00	12.50	14.25	13.50	15.06	12.56	14.31	13.44	15.00	15.44
14	16.25	13.75	15.50	14.75	16.31	13.81	15.56	14.69	16.25	16.69
16	18.50	15.75	17.62	16.75	18.56	15.81	17.69	16.69	18.50	18.94
18	21.00	17.75	20.12	19.25	21.06	17.81	20.19	19.19	21.00	21.44
20	23.00	19.75	22.00	21.00	23.06	19.81	22.06	20.94	23.00	23.44
24	27.25	23.75	26.25	25.25	27.31	23.81	26.31	25.19	27.25	27.69

Notes:

1. These dimensions apply to all ASME pressure classes except that the **large** facings are not available on Class 150 flanges.
2. Facing heights and groove depths must be added to basic "T" dimensions but they are included in overall length "OAL".

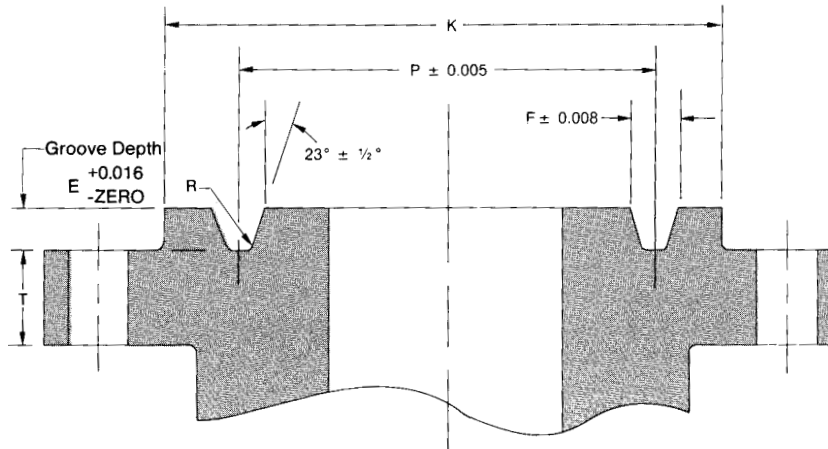

Ring Type Joint facings are available on all FVC connections per ASME B16.5

Ring Type Joint Facings

SIZE	CLASS	GROOVE NUMBER	P	E	F	R	K
1/2	300-600	R 11	1.344	0.219	0.281	0.03	2.00
	900-1500	R 12	1.562	0.250	0.344	0.03	2.38
	2500	R 13	1.688	0.250	0.344	0.03	2.56
3/4	300-600	R 13	1.688	0.250	0.344	0.03	2.50
	900-1500	R 14	1.750	0.250	0.344	0.03	2.62
	2500	R 16	2.000	0.250	0.344	0.03	2.88
1	150	R 15	1.875	0.250	0.344	0.03	2.50
	300-600	R 16	2.000	0.250	0.344	0.03	2.75
	900-1500	R 16	2.000	0.250	0.344	0.03	2.81
	2500	R 18	2.375	0.250	0.344	0.03	3.25
1 1/4	150	R 17	2.250	0.250	0.344	0.03	2.88
	300-600	R 18	2.375	0.250	0.344	0.03	3.12
	900-1500	R 18	2.375	0.250	0.344	0.03	3.19
	2500	R 21	2.844	0.312	0.469	0.03	4.00
1 1/2	150	R 19	2.562	0.250	0.344	0.03	3.25
	300-600	R 20	2.688	0.250	0.344	0.03	3.56
	900-1500	R 20	2.688	0.250	0.344	0.03	3.62
	2500	R 23	3.250	0.312	0.469	0.03	4.50
2	150	R 22	3.250	0.250	0.344	0.03	4.00
	300-600	R 23	3.250	0.312	0.469	0.03	4.25
	900-1500	R 24	3.750	0.312	0.469	0.03	4.88
	2500	R 26	4.000	0.312	0.469	0.03	5.25
2 1/2	150	R 25	4.000	0.250	0.344	0.03	4.75
	300-600	R 26	4.000	0.312	0.469	0.03	5.00
	900-1500	R 27	4.250	0.312	0.469	0.03	5.38
	2500	R 28	4.375	0.375	0.531	0.06	5.88
3	150	R 29	4.500	0.250	0.344	0.03	5.25
	300-600	R 31	4.875	0.312	0.469	0.03	5.75
	900	R 31	4.875	0.312	0.469	0.03	6.12
	1500	R 35	5.375	0.312	0.469	0.03	6.62
	2500	R 32	5.000	0.375	0.531	0.06	6.62

See notes on next page.



Ring Type Joint Facings

SIZE	CLASS	GROOVE NUMBER	P	E	F	R	K
3½	150 300-600	R 33	5.188	0.250	0.344	0.03	6.06
		R 34	5.188	0.312	0.469	0.03	6.25
4	150 300-600 900 1500 2500	R 36	5.875	0.250	0.344	0.03	6.75
		R 37	5.875	0.312	0.469	0.03	6.88
		R 37	5.875	0.312	0.469	0.03	7.12
		R 39	6.375	0.312	0.469	0.03	7.62
		R 38	6.188	0.438	0.656	0.06	8.00
5	150 300-600 900 1500 2500	R 40	6.750	0.250	0.344	0.03	7.62
		R 41	7.125	0.312	0.469	0.03	8.25
		R 41	7.125	0.312	0.469	0.03	8.50
		R 44	7.625	0.312	0.469	0.03	9.00
		R 42	7.500	0.500	0.781	0.06	9.50
6	150 300-900 1500 2500	R 43	7.625	0.250	0.344	0.03	8.62
		R 45	8.312	0.312	0.469	0.03	9.50
		R 46	8.312	0.375	0.531	0.06	9.75
		R 47	9.000	0.500	0.781	0.06	11.00
8	150 300-600 900 1500 2500	R 48	9.750	0.250	0.344	0.03	10.75
		R 49	10.625	0.312	0.469	0.03	11.88
		R 49	10.625	0.312	0.469	0.03	12.12
		R 50	10.625	0.438	0.656	0.06	12.50
		R 51	11.000	0.562	0.906	0.06	13.38
10	150 300-600 900 1500 2500	R 52	12.000	0.250	0.344	0.03	13.00
		R 53	12.750	0.312	0.469	0.03	14.00
		R 53	12.750	0.312	0.469	0.03	14.25
		R 54	12.750	0.438	0.656	0.06	14.62
		R 55	13.500	0.688	1.188	0.09	16.75
12	150 300-600 900 1500 2500	R 56	15.000	0.250	0.344	0.03	16.00
		R 57	15.000	0.312	0.469	0.03	16.25
		R 57	15.000	0.312	0.469	0.03	16.50
		R 58	15.000	0.562	0.906	0.06	17.25
		R 60	16.000	0.688	1.312	0.09	19.50
14	150 300-600 900 1500	R 59	15.625	0.250	0.344	0.03	16.75
		R 61	16.500	0.312	0.469	0.03	18.00
		R 62	16.500	0.438	0.656	0.06	18.38
		R 63	16.500	0.625	1.062	0.09	19.25
16	150 300-600 900 1500	R 64	17.875	0.250	0.344	0.03	19.00
		R 65	18.500	0.312	0.469	0.03	20.00
		R 66	18.500	0.438	0.656	0.06	20.62
		R 67	18.500	0.688	1.188	0.09	21.50
18	150 300-600 900 1500	R 68	20.375	0.250	0.344	0.03	21.50
		R 69	21.000	0.312	0.469	0.03	22.62
		R 70	21.000	0.500	0.781	0.06	23.38
		R 71	21.000	0.688	1.188	0.09	24.12
20	150 300-600 900 1500	R 72	22.000	0.250	0.344	0.03	23.50
		R 73	23.000	0.375	0.531	0.06	25.00
		R 74	23.000	0.500	0.781	0.06	25.50
		R 75	23.000	0.688	1.312	0.09	26.50
24	150 300-600 900 1500	R 76	26.500	0.250	0.344	0.03	28.00
		R 77	27.250	0.438	0.656	0.06	29.50
		R 78	27.250	0.625	1.062	0.09	30.38
		R 79	27.250	0.812	1.438	0.09	31.25

Notes: (A) Dimensions and tolerances are per ASME B16.5. (B) The facing thickness "E" is in addition to "T" dimension. "E" is included in overall length "OAL". (C) "K" and "R" dimensions are minimum dimensions.



Properties of Pipe

Nominal Pipe Size	O.D.	Pipe Sched.	Wall Thk.	I.D.	Weight per Foot
1/8	0.405	10S	0.049	0.307	0.186
		*40	0.068	0.269	0.244
		**80	0.095	0.215	0.314
1/4	0.540	10S	0.065	0.410	0.330
		*40	0.088	0.364	0.424
		**80	0.119	0.302	0.535
3/8	0.675	10S	0.065	0.545	0.423
		*40	0.091	0.493	0.567
		**80	0.126	0.423	0.738
1/2	0.840	5S	0.065	0.710	0.538
		10S	0.083	0.674	0.671
		*40	0.109	0.622	0.850
		**80	0.147	0.546	1.087
		160	0.188	0.464	1.310
XX-STG	0.294	0.252	1.714		
3/4	1.050	5S	0.065	0.920	0.684
		10S	0.083	0.884	0.857
		*40	0.113	0.824	1.130
		**80	0.154	0.742	1.473
		160	0.219	0.612	1.940
XX-STG	0.308	0.434	2.440		
1	1.315	5S	0.065	1.185	0.868
		10S	0.109	1.097	1.404
		*40	0.133	1.049	1.678
		*80	0.179	0.957	2.171
		160	0.250	0.815	2.850
XX-STG	0.358	0.599	3.659		
1¼	1.660	5S	0.065	1.530	1.107
		10S	0.109	1.442	1.806
		*40	0.140	1.380	2.272
		**80	0.191	1.278	2.996
		160	0.250	1.160	3.764
XX-STG	0.382	0.896	5.214		
1½	1.900	5S	0.065	1.770	1.274
		10S	0.109	1.682	2.085
		*40	0.145	1.610	2.717
		**80	0.200	1.500	3.631
		160	0.281	1.338	4.862
XX-STG	0.400	1.100	6.408		
2	2.375	5S	0.065	2.245	1.604
		10S	0.109	2.157	2.638
		*40	0.154	2.067	3.652
		**80	0.218	1.939	5.022
		160	0.344	1.687	7.450
XX-STG	0.436	1.503	9.029		
2½	2.875	5S	0.083	2.709	2.48
		10S	0.120	2.635	3.53
		*40	0.203	2.469	5.79
		**80	0.276	2.323	7.66
		160	0.375	2.125	10.01
XX-STG	0.552	1.771	13.69		

Nominal Pipe Size	O.D.	Pipe Sched.	Wall Thk.	I.D.	Weight per Foot
3	3.500	5S	0.083	3.334	3.03
		10S	0.120	3.260	4.33
		*40	0.216	3.068	7.57
		**80	0.300	2.900	10.25
		160	0.438	2.624	14.32
XX-STG	0.600	2.300	18.58		
3½	4.000	5S	0.083	3.834	3.47
		10S	0.120	3.760	4.97
		*40	0.226	3.548	9.11
		**80	0.318	3.364	12.51
4	4.500	5S	0.083	4.334	3.92
		10S	0.120	4.260	5.61
		*40	0.237	4.026	10.79
		**80	0.337	3.826	14.98
		120	0.438	3.624	19.00
		160	0.531	3.438	22.60
XX-STG	0.674	3.152	27.54		
5	5.563	5S	0.109	5.345	6.35
		10S	0.134	5.295	7.77
		*40	0.258	5.047	14.62
		**80	0.375	4.813	20.78
		120	0.500	4.563	27.10
160	0.625	4.313	32.96		
XX-STG	0.750	4.063	38.55		
6	6.625	5S	0.109	6.407	7.59
		10S	0.134	6.357	9.29
		*40	0.280	6.065	18.97
		**80	0.432	5.761	28.57
		120	0.562	5.501	36.40
160	0.719	5.187	45.30		
XX-STG	0.864	4.897	53.16		
8	8.625	5S	0.109	8.407	10
		10S	0.148	8.329	13
		20	0.250	8.125	22
		30	0.277	8.071	25
		*40	0.322	7.981	29
		60	0.406	7.813	36
		**80	0.500	7.625	43
		100	0.594	7.437	51
		120	0.719	7.187	61
		140	0.812	7.001	68
160	0.906	6.813	75		
XX-STG	0.875	6.875	72		

* SCH 40, SCH 40S, and STD. WT. are the same 1/8" N.P.S. thru 10" N.P.S. inclusive

** SCH 80, SCH 80S, and X-STG are the same 1/8" N.P.S. thru 8" N.P.S. inclusive

s Includes STD. WT.

t Includes X-STG



Properties of Pipe

Nominal Pipe Size	O.D.	Pipe Sched.	Wall Thk.	I.D.	Weight per Foot
10	10.750	5S	0.134	10.482	15
		10S	0.165	10.420	19
		20	0.250	10.250	28
		30	0.307	10.136	34
		*40	0.365	10.020	40
		60	0.500	9.750	55
		† 80S	0.500	9.750	55
		80	0.594	9.562	64
		100	0.719	9.312	77
		120	0.844	9.062	89
		140	1.000	8.750	104
		160	1.125	8.500	116
		XX-STG	1.000	8.750	104
12	12.750	5S	0.156	12.438	21
		10S	0.180	12.390	24
		20	0.250	12.250	33
		30	0.330	12.090	44
		‡ 40S	0.375	12.000	50
		40	0.406	11.938	54
		60	0.562	11.626	73
		† 80S	0.500	11.750	65
		80	0.688	11.374	89
		100	0.844	11.062	108
		120	1.000	10.750	126
		140	1.125	10.500	140
		160	1.312	10.126	161
XX-STG	1.000	10.750	126		
14	14.000	5S	0.156	13.688	23
		10S	0.188	13.624	28
		10	0.250	13.500	37
		20	0.312	13.376	46
		30	0.375	13.250	55
		STD.WT.	0.375	13.250	55
		40	0.438	13.124	63
		60	0.594	12.812	85
		X-STG	0.500	13.000	72
		80	0.750	12.500	107
		100	0.938	12.124	131
		120	1.094	11.812	151
		140	1.250	11.500	171
160	1.406	11.188	190		
16	16.000	5S	0.165	15.670	28
		10S	0.188	15.624	32
		10	0.250	15.500	42
		20	0.312	15.375	52
		30	0.375	15.250	63
		STD.WT.	0.375	15.250	63
		40	0.500	15.000	83
		60	0.656	14.688	108
		X-STG	0.500	15.000	83
		80	0.844	14.312	137
		100	1.031	13.938	165
		120	1.219	13.562	193
		140	1.438	13.124	224
160	1.594	12.812	245		

Nominal Pipe Size	O.D.	Pipe Sched.	Wall Thk.	I.D.	Weight per Foot
18	18.000	5S	0.165	17.670	31
		10S	0.188	17.624	36
		10	0.250	17.500	47
		20	0.312	17.375	59
		30	0.438	17.124	82
		STD.WT.	0.375	17.250	71
		40	0.562	16.876	105
		60	0.750	16.500	138
		X-STG	0.500	17.000	93
		80	0.938	16.124	171
		100	1.156	15.688	208
		120	1.375	15.250	244
		140	1.562	14.876	275
160	1.781	14.438	309		
20	20.000	5S	0.188	19.624	40
		10S	0.218	19.564	46
		10	0.250	19.500	53
		20	0.375	19.250	79
		30	0.500	19.000	105
		STD.WT.	0.375	19.250	79
		40	0.594	18.812	123
		60	0.812	18.376	167
		X-STG	0.500	19.000	105
		80	1.031	17.938	209
		100	1.281	17.438	256
		120	1.500	17.000	297
		140	1.750	16.500	342
160	1.969	16.062	379		
24	24.000	5S	0.218	23.564	55
		10S	0.250	23.500	63
		10	0.250	23.500	63
		20	0.375	23.250	95
		30	0.562	22.876	141
		STD.WT.	0.375	23.250	95
		40	0.688	22.624	171
		60	0.969	22.062	238
		X-STG	0.500	23.000	125
		80	1.219	21.562	297
		100	1.531	20.938	367
		120	1.812	20.376	429
		140	2.062	19.876	484
160	2.344	19.312	542		

Notes:

- A) All dimensions are in inches.
- B) All weights are in pounds.
- C) Dimensions for STD WT., X-STG, XX-STG, SCH 10, 20, 30, 40, 60, 80, 100, 120, 140 and 160 are in conformance with ANSI B36.10.
- D) Dimensions for SCH 5S, 10S, 40S and 80S are in conformance with ANSI B36.19.



Pressure-Temperature Ratings

THE FOLLOWING TABLE AND NOTES DETAIL THE MATERIALS FOR THE ASME B16.5 PRESSURE-TEMPERATURE CHARTS:

Material Group	Material	See Notes
1.1	A-105	a,h,j
	A-515-70	a,h
	A-516-70	a,g
	A-350-LF2,A-537 C1.1	d
1.2	A-203-B, A-203-E	a,h
	A-350-LF3	d
1.4	A-515-60	a,h
	A-516-60	a,g
	A-350-LF1	d
1.5	A-182-F1, A-204-A, A-204-B	b,h
1.7	A-204-C	g
	A-182-F2	h
1.9	A-182-F11 C1.2, A-182-F12	c,k
	A-387-11 C1.2	c
1.10	A-182-F22 C1.3, A-387-22 C1.2	c
1.13	A-182-F5A, A-182-F5	-
1.14	A-182-F9	-

Material Group	Material	See Notes
2.1	A-182-F304	l
	A-182-F304H	-
	A-240-304, A-240-304H	l,m
2.2	A-182-F316	l
	A-182-F316H	-
	A-240-316, A-240-316H, A-240-317	l,m
2.3	A-182-F304L, A-240-304L	f
	A-182-F316L, A-240-316L	g
2.4	A-182-F321	h,l
	A-240-321	h,l,m
	A-182-F321H	-
2.5	A-240-321H	m
	A-182-F347	h,i
	A-240-347	h,l,m
	A-182-F347H	-
	A-240-347H	m
	A-182-F348	h,l
2.6	A-240-348	h,l,m
	A-182-F348H	-
2.7	A-240-348H	m
	A-240-309S, A-240-309H	l,m
2.7	A-182-F310, A-240-310S, A-240-310H	i,l,n

General Note:

Plate materials are listed only for use as blind flanges. For more details see ASME B16.5.

Notes:

- a. Permissible but not recommended for prolonged use above about 800°F (425°C).
- b. Permissible but not recommended for prolonged use above about 850°F (455°C).
- c. Permissible but not recommended for prolonged use above about 1100°F (593°C).
- d. Not to be used over 650°F (343°C).
- f. Not to be used over 800°F (425°C).
- g. Not to be used over 850°F (455°C).
- h. Not to be used over 1000°F (540°C).
- i. For service temperature 1050°F (566°C) and above, assurance must be provided that grain size is not finer than ASTM No. 6.
- j. Only killed steel may be used above 850°F (455°C).
- k. Use normalized and tempered material only.
- l. At temperatures over 1000°F (540°C), use only when the carbon content is 0.04 percent or higher.
- m. For temperatures over 1000°F (540°C), use only if the material is heat treated by heating it to a temperature of at least 1900°F (1040°C) and quenching in water or rapidly cooling by other means.
- n. For service temperatures of 1050°F (566°C) and above, assurance must be provided that grain size is not finer than ASTM No. 6.
- o. To be used only for Class 150 and Class 300 flanges.



Pressure-Temperature Ratings

Class 150

Material Group	1.1*	1.2	1.4	1.5	1.7	1.9	1.10	1.13	1.14	2.1	2.2	2.3	2.4	2.5	2.6	2.7	
-20° to 100°	285	290	235	265	290	290	290	290	290	275	275	230	275	275	260	260	100°
200°	260	260	215	260	260	260	260	260	260	235	240	195	235	245	230	230	200°
300°	230	230	210	230	230	230	230	230	230	205	215	175	210	225	220	220	300°
400°	200	200	200	200	200	200	200	200	200	180	195	160	190	200	200	200	400°
500°	170	170	170	170	170	170	170	170	170	170	170	145	170	170	170	170	500°
600°	140	140	140	140	140	140	140	140	140	140	140	140	140	140	140	140	600°
650°	125	125	125	125	125	125	125	125	125	125	125	125	125	125	125	125	650°
700°	110	110	110	110	110	110	110	110	110	110	110	110	110	110	110	110	700°
750°	95	95	95	95	95	95	95	95	95	95	95	95	95	95	95	95	750°
800°	80	80	80	80	80	80	50	80	80	80	80	80	80	80	80	80	800°
850°	65	65	65	65	65	65	65	65	65	65	65	65	65	65	65	65	850°
900°	50	50	50	50	50	50	50	50	50	50	50	-	50	50	50	50	900°
950°	35	35	35	35	35	35	35	35	35	35	35	-	35	35	35	35	950°
1000°	20	20	20	20	20	20	20	20	20	20	20	-	20	20	20	20	1000°

- Notes:** 1. See temperature notes for all materials (page 68).
 2. Pressures are in pounds per square inch, gage (psig)
 † 316L ONLY
 * material Group 1.1 includes: SA-105, SA-515-70, SA-516-70, SA-350-LF2, SA-537 C1.1

Pressure-Temperature Ratings

Class 300

Material Group	1.1 _s	1.2	1.4	1.5	1.7	1.9	1.10	1.13	1.14	2.1	2.2	2.3	2.4	2.5	2.6	2.7	
-20° to 100°	740	750	620	695	750	750	750	750	750	720	720	600	720	720	670	670	100°
200°	675	750	560	680	750	710	715	750	750	600	620	505	610	635	605	605	200°
300°	655	730	550	655	730	675	675	730	730	530	560	455	545	590	570	570	300°
400°	635	705	530	640	705	660	650	705	705	470	515	415	495	555	535	535	400°
500°	600	665	500	620	665	640	640	665	665	435	480	380	460	520	505	505	500°
600°	550	605	455	605	605	605	605	605	605	415	450	360	435	490	480	480	600°
650°	535	590	450	590	590	590	590	590	590	410	445	350	430	480	465	465	650°
700°	535	570	450	570	570	570	570	570	570	405	430	345	420	470	455	455	700°
750°	505	505	445	530	530	530	530	530	530	400	425	335	415	460	445	445	750°
800°	410	410	370	510	510	510	510	500	510	395	415	330	415	455	435	435	800°
850°	270	270	270	485	485	485	485	440	485	390	405	320	410	445	425	425	850°
900°	170	170	170	450	450	450	450	355	450	385	395	-	405	430	415	415	900°
950°	105	105	105	280	345	380	380	260	370	375	385	-	385	385	385	385	950°
1000°	50	50	50	165	215	225	270	190	290	325	365	-	355	365	335	350	1000°
1050°					190	140	200	140	190	310	360	-	345	360	290	335	1050°
1100°						95	115	105	115	260	325	-	300	325	225	290	1100°
1150°						50	105	70	75	195	275	-	235	275	170	245	1150°
1200°						35	55	45	50	155	205	-	180	170	130	205	1200°
1250°										110	180	-	140	125	100	160	1250°
1300°										85	140	-	105	95	80	120	1300°
1350°										60	105	-	80	70	60	80	1350°
1400°										50	75	-	60	50	45	55	1400°
1450°										35	60	-	50	40	30	40	1450°
1500°										25	40	-	40	35	25	25	1500°

- Notes:**
 1. See temperature notes for all materials (page 68)
 2. Pressures are in pounds per square inch, gage (psig)



Pressure-Temperature Ratings

Class 400

Material Group	1.1 _s	1.2	1.4	1.5	1.7	1.9	1.10	1.13	1.14	2.1	2.2	2.3	2.4	2.5	2.6	2.7	Temperature (Fahrenheit)
-20° to 100°	990	1000	825	925	1000	1000	1000	1000	1000	960	960	800	960	960	895	895	100°
200°	900	1000	750	905	1000	950	955	1000	1000	800	825	675	815	850	805	805	200°
300°	875	970	730	870	970	895	905	970	970	705	745	605	725	785	760	760	300°
400°	845	940	705	855	940	880	865	940	940	630	685	550	660	740	710	710	400°
500°	800	885	665	830	885	855	855	885	885	585	635	510	610	690	670	670	500°
600°	730	805	610	805	805	805	805	805	805	555	600	480	585	655	635	635	600°
650°	715	785	600	785	785	785	785	785	785	545	590	470	570	640	620	620	650°
700°	710	755	600	755	755	755	755	755	755	540	575	460	560	625	610	610	700°
750°	670	670	590	710	710	710	710	710	710	530	565	450	555	615	595	595	750°
800°	550	550	495	675	675	675	675	665	675	525	555	440	550	610	580	580	800°
850°	355	355	355	650	650	650	650	585	650	520	540	430	545	590	565	565	850°
900°	230	230	230	600	600	600	600	470	600	510	525	-	540	575	555	555	900°
950°	140	140	140	375	460	505	505	350	495	500	515	-	515	515	515	515	950°
1000°	70	70	70	220	285	300	355	255	390	430	485	-	475	485	450	465	1000°
1050°	t 316L ONLY s Material Group 1.1 includes: SA-105, SA-515-70, SA-516-70, SA-350-LF2, SA-537 C1.1				250	185	265	190	250	410	480	-	460	480	390	445	1050°
1100°					130	150	140	150	345	430	-	400	430	300	390	1100°	
1150°					70	140	90	100	260	365	-	315	365	230	330	1150°	
1200°	Notes: 1. See temperature notes for all materials (page 68) 2. Pressures are in pounds per square inch, gage (psig)				45	75	60	70	205	275	-	240	230	175	275	1200°	
1250°					145	245	-	185	165	135	215	1250°					
1300°					110	185	-	140	125	105	160	1300°					
1350°	Notes: 1. See temperature notes for all materials (page 68) 2. Pressures are in pounds per square inch, gage (psig)				85	140	-	110	90	80	105	1350°					
1400°					65	100	-	80	70	60	75	1400°					
1450°					45	80	-	65	55	40	50	1450°					
1500°	Notes: 1. See temperature notes for all materials (page 68) 2. Pressures are in pounds per square inch, gage (psig)				30	55	-	50	45	30	30	1500°					
1500°					Notes: 1. See temperature notes for all materials (page 68) 2. Pressures are in pounds per square inch, gage (psig)				30	55	-	50	45	30	30	1500°	
1500°									Notes: 1. See temperature notes for all materials (page 68) 2. Pressures are in pounds per square inch, gage (psig)				30	55	-	50	45

Pressure-Temperature Ratings

Class 600

Material Group	1.1 _s	1.2	1.4	1.5	1.7	1.9	1.10	1.13	1.14	2.1	2.2	2.3	2.4	2.5	2.6	2.7	Temperature (Fahrenheit)
-20° to 100°	1480	1500	1235	1390	1500	1500	1500	1500	1500	1440	1440	1200	1440	1440	1345	1345	100°
200°	1350	1500	1125	1360	1500	1425	1430	1500	1500	1200	1240	1015	1220	1270	1210	1210	200°
300°	1315	1455	1095	1305	1455	1345	1355	1455	1455	1055	1120	910	1090	1175	1140	1140	300°
400°	1270	1410	1060	1280	1410	1315	1295	1410	1410	940	1030	825	990	1110	1065	1065	400°
500°	1200	1330	995	1245	1330	1285	1280	1330	1330	875	955	765	915	1035	1010	1010	500°
600°	1095	1210	915	1210	1210	1210	1210	1210	1210	830	905	720	875	985	955	955	600°
650°	1075	1175	895	1175	1175	1175	1175	1175	1175	815	890	700	855	960	930	930	650°
700°	1065	1135	895	1135	1135	1135	1135	1135	1135	805	865	685	840	935	910	910	700°
750°	1010	1010	885	1065	1065	1065	1065	1065	1065	795	845	670	830	920	895	895	750°
800°	825	825	740	1015	1015	1015	1015	995	1015	790	830	660	825	910	870	870	800°
850°	535	5.35	535	975	975	975	975	880	975	780	810	645	815	860	850	850	850°
900°	345	345	345	900	900	900	900	705	900	770	790	-	810	865	830	830	900°
950°	205	205	205	560	685	755	755	520	740	750	775	-	775	775	775	775	950°
1000°	105	105	105	330	425	445	535	385	585	645	725	-	715	725	670	700	1000°
1050°	t 316L ONLY s Material Group 1.1 includes: SA-105, SA-515-70, SA-516-70, SA-350-LF2, SA-537 C1.1				380	275	400	280	380	620	720	-	695	720	585	665	1050°
1100°					190	225	205	225	515	645	-	605	645	445	585	1100°	
1150°					105	205	140	150	390	550	-	475	550	345	495	1150°	
1200°	Notes: 1. See temperature notes for all materials (page 68) 2. Pressures are in pounds per square inch, gage (psig)				70	110	90	105	310	410	-	365	345	260	410	1200°	
1250°					220	365	-	280	245	200	325	1250°					
1300°					165	275	-	210	185	160	240	1300°					
1350°	Notes: 1. See temperature notes for all materials (page 68) 2. Pressures are in pounds per square inch, gage (psig)				125	205	-	165	135	115	160	1350°					
1400°					90	150	-	125	105	90	110	1400°					
1450°					70	115	-	95	80	60	75	1450°					
1500°	Notes: 1. See temperature notes for all materials (page 68) 2. Pressures are in pounds per square inch, gage (psig)				50	85	-	75	70	50	50	1500°					
1500°					Notes: 1. See temperature notes for all materials (page 68) 2. Pressures are in pounds per square inch, gage (psig)				50	85	-	75	70	50	50	1500°	
1500°									Notes: 1. See temperature notes for all materials (page 68) 2. Pressures are in pounds per square inch, gage (psig)				50	85	-	75	70



Pressure-Temperature Ratings

Class 900

Material Group	1.1 _s	1.2	1.4	1.5	1.7	1.9	1.10	1.13	1.14	2.1	2.2	2.3	2.4	2.5	2.6	2.7	Temperature (Fahrenheit)	
-20° to 100°	2220	2250	1850	2085	2250	2250	2250	2250	2250	2160	2160	1800	2160	2160	2015	2015	100°	
200°	2025	2250	1685	2035	2250	2135	2150	2250	2250	1800	1860	1520	1830	1910	1815	1815	200°	
300°	1970	2185	1640	1955	2185	2020	2030	2185	2185	1585	1680	1360	1635	1765	1705	1705	300°	
400°	1900	2115	1585	1920	2115	1975	1945	2115	2115	1410	1540	1240	1485	1665	1600	1600	400°	
500°	1795	1995	1495	1865	1995	1925	1920	1995	1995	1310	1435	1145	1375	1555	1510	1510	500°	
600°	1640	1815	1370	1815	1815	1815	1815	1815	1815	1245	1355	1080	1310	1475	1435	1435	600°	
650°	1610	1765	1345	1765	1765	1765	1765	1765	1765	1225	1330	1050	1280	1440	1395	1395	650°	
700°	1600	1705	1345	1705	1705	1705	1705	1705	1705	1210	1295	1030	1260	1405	1370	1370	700°	
750°	1510	1510	1325	1595	1595	1595	1595	1595	1595	1195	1270	1010	1245	1385	1340	1340	750°	
800°	1235	1235	1110	1525	1525	1525	1525	1490	1525	1180	1245	985	1240	1370	1305	1305	800°	
850°	805	805	805	1460	1460	1460	1460	1315	1460	1165	1215	965	1225	1330	1275	1275	850°	
900°	515	515	515	1350	1350	1350	1350	1060	1350	1150	1180	-	1215	1295	1245	1245	900°	
950°	310	310	310	845	1030	1130	1130	780	1110	1125	1160	-	1160	1160	1160	1160	950°	
1000°	155	155	155	495	640	670	805	575	875	965	1090	-	1070	1090	1010	1050	1000°	
1050°					565	410	595	420	565	925	1080	-	1040	1080	875	1000	1050°	
1100°						290	340	310	340	770	965	-	905	965	670	875	1100°	
1150°	† 316L ONLY ‡ Material Group 1.1 includes: SA-105, SA-515-70, SA-516-70, SA-350-LF2, SA-537 C1.1					155	310	205	225	585	825	-	710	825	515	740	1150°	
1200°						105	165	135	155	465	620	-	545	515	390	620	1200°	
1250°											330	545	-	420	370	300	485	1250°
1300°											245	410	-	320	280	235	360	1300°
1350°										185	310	-	245	205	175	235	1350°	
1400°										145	225	-	185	155	135	165	1400°	
1450°										105	175	-	145	125	95	115	1450°	
1500°										70	125	-	115	105	70	70	1500°	

Pressure-Temperature Ratings

Class 1500

Material Group	1.1 _s	1.2	1.4	1.5	1.7	1.9	1.10	1.13	1.14	2.1	2.2	2.3	2.4	2.5	2.6	2.7	Temperature (Fahrenheit)
-20° to 100°	3705	3750	3085	3470	3750	3750	3750	3750	3750	3600	3600	3000	3600	3600	3360	3360	100°
200°	3375	3750	2810	3395	3750	3560	3580	3750	3750	3000	3095	2530	3050	3180	3025	3025	200°
300°	3280	3640	2735	3260	3640	3365	3385	3640	3640	2640	2795	2270	2725	2940	2845	2845	300°
400°	3170	3530	2645	3200	3530	3290	3240	3530	3530	2350	2570	2065	2470	2770	2665	2665	400°
500°	2995	3325	2490	3105	3325	3210	3200	3325	3325	2185	2390	1910	2290	2590	2520	2520	500°
600°	2735	3025	2285	3025	3025	3025	3025	3025	3025	2075	2255	1800	2185	2460	2390	2390	600°
650°	2685	2940	2245	2940	2940	2940	2940	2940	2940	2040	2220	1750	2135	2400	2330	2330	650°
700°	2665	2840	2245	2840	2840	2840	2840	2840	2840	2015	2160	1715	2100	2340	2280	2280	700°
750°	2520	2520	2210	2660	2660	2660	2660	2660	2660	1990	2110	1680	2075	2305	2230	2230	750°
800°	2060	2060	1850	2540	2540	2540	2540	2485	2540	1970	2075	1645	2065	2280	2170	2170	800°
850°	1340	1340	1340	2435	2435	2435	2435	2195	2435	1945	2030	1610	2040	2220	2125	2125	850°
900°	860	860	860	2245	2245	2245	2245	1765	2245	1920	1970	-	2030	2160	2075	2075	900°
950°	515	515	515	1405	1715	1885	1885	1305	1850	1870	1930	-	1930	1930	1930	1930	950°
1000°	260	260	260	825	1065	1115	1340	960	1460	1610	1820	-	1785	1820	1680	1750	1000°
1050°					945	685	995	705	945	1545	1800	-	1730	1800	1460	1665	1050°
1100°						480	565	515	565	1285	1610	-	1510	1610	1115	1460	1100°
1150°	† 316L ONLY ‡ Material Group 1.1 includes: SA-105, SA-515-70, SA-516-70, SA-350-LF2, SA-537 C1.1					260	515	345	380	980	1370	-	1185	1370	860	1235	1150°
1200°						170	275	225	260	770	1030	-	910	855	650	1030	1200°
1250°										550	910	-	705	615	495	805	1250°
1300°										410	685	-	530	465	395	600	1300°
1350°										310	515	-	410	345	290	395	1350°
1400°										240	380	-	310	255	225	275	1400°
1450°										170	290	-	240	205	155	190	1450°
1500°										120	205	-	190	170	120	120	1500°



Pressure-Temperature Ratings

Class 2500

Material Group	1.1 _s	1.2	1.4	1.5	1.7	1.9	1.10	1.13	1.14	2.1	2.2	2.3	2.4	2.5	2.6	2.7	Temperature (Fahrenheit)
-20° to 100°	6170	6250	5145	5785	6250	6250	6250	6250	6250	6000	6000	5000	6000	6000	5600	5600	100°
200°	5625	6250	4680	5660	6250	5930	5965	6250	6250	5000	5160	4220	5080	5300	5040	5040	200°
300°	5470	6070	4560	5435	6070	5605	5640	6070	6070	4400	4660	3780	4540	4900	4740	4740	300°
400°	5280	5880	4405	5330	5880	5485	5400	5880	5880	3920	4280	3440	4120	4620	4440	4440	400°
500°	4990	5540	4150	5180	5540	5350	5330	5540	5540	3640	3980	3180	3820	4320	4200	4200	500°
600°	4560	5040	3805	5040	5040	5040	5040	5040	5040	3460	3760	3000	3640	4100	3980	3980	600°
650°	4475	4905	3740	4905	4905	4905	4905	4905	4905	3400	3700	2920	3560	4000	3880	3880	650°
700°	4440	4730	3740	4730	4730	4730	4730	4730	4730	3360	3600	2860	3500	3900	3800	3800	700°
750°	4200	4200	3685	4430	4430	4430	4430	4430	4430	3320	3520	2800	3460	3840	3720	3720	750°
800°	3430	3430	3085	4230	4230	4230	4230	4145	4230	3280	3460	2740	3440	3800	3620	3620	800°
850°	2230	2230	2230	4060	4060	4060	4060	3660	4060	3240	3380	2680	3400	3700	3540	3540	850°
900°	1430	1430	1430	3745	3745	3745	3745	2945	3745	3200	3280	-	3380	3600	3460	3460	900°
950°	860	860	860	2345	2860	3145	3145	2170	3085	3120	3220	-	3220	3220	3220	3220	950°
1000°	430	430	430	1370	1770	1860	2230	1600	2430	2685	3030	-	2970	3030	2800	2915	1000°
1050°	t 316L ONLY s Material Group 1.1 includes: SA-105, SA-515-70, SA-516-70, SA-350-LF2, SA-537 C1.1 Notes: 1. See temperature notes for all materials (page 68) 2. Pressures are in pounds per square inch, gage (psig)				1570	1145	1660	1170	1570	2570	3000	-	2885	3000	2430	2770	1050°
1100°					800	945	860	945	2145	2685	-	2515	2685	1860	2430	1100°	
1150°					430	860	570	630	1630	2285	-	1970	2285	1430	2060	1150°	
1200°					285	460	370	430	1285	1715	-	1515	1430	1085	1715	1200°	
1250°									915	1515	-	1170	1030	830	1346	1250°	
1300°					685	1145	-	885	770	660	1000	1300°					
1350°					515	860	-	685	570	485	660	1350°					
1400°					400	630	-	515	430	370	460	1400°					
1450°					285	485	-	400	345	260	315	1450°					
1500°					200	345	-	315	285	200	200	1500°					

Maximum Allowable Hydrostatic Test Pressures (At Ambient Temperature)

Material Group	Shell Test Pressures (All Pressures Are Gage)						
	CLASS 150	CLASS 300	CLASS 400	CLASS 600	CLASS 900	CLASS 1500	CLASS 2500
	1.1	450	1125	1500	2225	3350	5575
1.2	450	1125	1500	2250	3375	5625	9375
1.4	375	950	1250	1875	2775	4650	7725
1.5	400	1050	1400	2100	3150	5225	8700
1.7	450	1125	1500	2250	3375	5625	9375
1.9	450	1125	1500	2250	3375	5625	9375
1.10	450	1125	1500	2250	3375	5625	9375
1.13	450	1125	1500	2250	3375	5625	9375
1.14	450	1125	1500	2250	3375	5625	9375
2.1	425	1100	1450	2175	3250	5400	9000
2.2	425	1100	1450	2175	3250	5400	9000
2.3	350	900	1200	1800	2700	4500	7500
2.4	425	1100	1450	2175	3250	5400	9000
2.5	425	1100	1450	2175	3250	5400	9000
2.6	400	1025	1350	2025	3025	5050	8400
2.7	400	1025	1350	2025	3025	5050	8400



Flange Bolting Information

Dimensions of Bolts with Heavy Hex Heads and Nuts (ASME B18.2)

Bolt Size	Thread Dimensions		Nut Dimensions		Nom. Nut Thick.	FVC Nut Stop Dia. = Flange Bolt Circle Less:
	Threads Per Inch	Root Area	Across Flats	Across Corners		
1/2	13	0.126	0.875	0.969	0.484	0.875
5/8	11	0.202	1.063	1.175	0.609	1.063
3/4	10	0.302	1.250	1.383	0.734	1.250
7/8	9	0.419	1.438	1.589	0.859	1.438
1	8	0.551	1.625	1.796	0.984	1.625
1 1/8	8	0.728	1.813	2.002	1.109	1.813
1 1/4	8	0.929	2.000	2.209	1.219	2.000
1 3/8	8	1.155	2.188	2.416	1.344	2.188
1 1/2	8	1.405	2.375	2.622	1.469	2.375
1 5/8	8	1.680	2.563	2.828	1.594	2.563
1 3/4	8	1.980	2.750	3.035	1.719	2.750
1 7/8	8	2.300	2.938	3.242	1.844	2.938
2	8	2.650	3.125	3.449	1.969	3.125
2 1/4	8	3.420	3.500	3.862	2.203	3.500
2 1/2	8	4.290	3.875	4.275	2.453	3.875
2 3/4	8	5.260	4.250	4.688	2.703	4.250
3	8	6.320	4.625	5.102	2.953	4.625
3 1/4	8	7.490	5.000	5.515	3.188	5.000
3 1/2	8	8.750	5.375	5.928	3.438	5.375
3 3/4	8	10.110	5.750	6.341	3.688	5.750
4	8	11.570	6.125	6.755	3.938	6.125

Bolting Materials

Nominal Composition	Specification Number	Grade	Application
Carbon and Low Alloy Steels			
C	SA-307	B	Structural
C	SA-325	Type 1, 2, 3	Structural
C	SA-354	BC, BD	High Strength Service (650°F max.)
Cr-Mo	SA-193	65	High Strength Service (1200°F max.)
Cr-Mo	SA-193	B7	High Strength Service (1000°F max.)
Cr-Mo-V	SA-193	B16	High Strength Service (1100°F max.)
Cr-Mo	SA-320	L7	Low Temperature Service
High Alloy Steels			
Cr-Ni	SA-193	B8, B8M	Stainless Steel Flanges
Cr-Ni	SA-320	B8, B8M	Structural
Cr-Ni-Mo	SA-453	660	High Strength Stainless Steel



Conversions

Change	To	Multiply by
atmospheres	ft of water (at 4° C)	33.90
atmospheres	in of mercury (at 0° C)	29.92
atmospheres	kgs/sq cm	1.0333
atmospheres	pounds/sq in	14.70
bars	atmospheres	0.9869
btu	foot-lbs	778.3
btu	joules	1,054.8
btu	kilowatt-hrs	2.928 x 10 ⁻⁴
calories, gram (mean)	btu (mean)	3.9685 x 10 ⁻³
centigrade	fahrenheit	(C°x9/5) + 32
centimeters	feet	3.281 x 10 ⁻²
centimeters	inches	0.3937
centimeters	kilometers	10 ⁻⁵
centimeters	meters	0.01
centimeters	millimeters	10.0
cubic centimeters	cu feet	3.531 x 10 ⁻⁵
cubic centimeters	cu inches	0.06102
cubic centimeters	cu meters	10 ⁻⁶
cubic centimeters	gallons (U.S. liq)	2.642 x 10 ⁻⁴
cubic centimeters	liters	0.001
cubic feet	cu inches	1,728.0
cubic feet	cu meters	0.02832
cubic feet	gallons (U.S. liq)	7.48052
cubic feet	liters	28.32
cubic inches	cu cms	16.39
cubic inches	cu feet	5.787 x 10 ⁻⁴
cubic inches	cu meters	1.639 x 10 ⁻⁵
cubic inches	gallons	4.329 x 10 ⁻³
cubic meters	cu cms	10 ⁶
cubic meters	cu feet	35.31
cubic meters	cu inches	61,023.0
cubic meters	gallons (u.s. liq)	264.2
cubic meters	liters	1,000.0
dynes	joules/cm	10 ⁻⁷
dynes	joules/meter (newtons)	10 ⁻⁵
dynes	kilograms	1.020 x 10 ⁻⁶
dynes	poundals	7.233 x 10 ⁻⁵
dynes	pounds	2.248 x 10 ⁻⁶
ergs	BTU	9.480 x 10 ⁻¹¹
ergs	foot-pounds	7.367 x 10 ⁻⁸
ergs	joules	10 ⁻⁷
ergs/sec	horsepower	1.341 x 10 ⁻¹⁰
feet	centimeters	30.48
feet	meters	0.3048
feet	millimeters	304.8
feet	inches	12.0
feet of water	atmospheres	0.02950
feet of water	in of mercury	0.8826
feet of water	pounds/sq ft	62.43
feet of water	pounds/sq in	0.4335
fahrenheit	centigrade	(°F- 32) x 5/9
foot-pounds	BTU	1.286 x 10 ⁻³
foot-pounds	ergs	1.356 x 10 ⁷
foot-pounds	joules	1.356
foot-pounds	kilowatt-hrs	3.766 x 10 ⁻⁷

Change	To	Multiply by
gallons	cu cms	3,785.0
gallons	cu feet	0.1337
gallons	cu inches	231.0
gallons	cu meters	3.785 x 10 ⁻³
gallons	liters	3.785
gallons (liq Br. Imp.)	gallons (U.S. liq)	1.20095
gallons (U.S.)	gallons (Imp.)	0.83267
gallons of water	pounds of water	8.3453
grams	dynes	980.7
grams	kilograms	0.001
grams	milligrams	1,000.0
grams	ounces(avdp)	0.03527
grams	ounces (troy)	0.03215
grams	poundals	0.07093
grams	pounds	2.205 x 10 ⁻³
grams/cu cm	pounds/cu ft	62.43
grams/cu cm	pounds/cu in	0.03613
grams/sq cm	pounds/sq ft	2.0481
horsepower	BTU/min	42.44
horsepower	foot-lbs/min	33,000.0
horsepower	foot-lbs/sec	550.0
horsepower	kilowatts	0.7457
horsepower	watts	745.7
inches	centimeters	2.540
inches	meters	2.540 x 10 ⁻²
inches	millimeters	25.40
inches	mils	1,000.0
inches	feet	0.0833
inches of mercury	atmospheres	0.03342
inches of mercury	inches of water	13.6
inches of mercury	feet of water	1.1333
inches of mercury	kgs/sq cm	0.03453
inches of mercury	kgs/sq meter	345.3
inches of mercury	pounds/sq ft	70.73
inches of mercury	pounds/sq in	0.4912
inches of water (at 4°C)	atmospheres	2.458 x 10 ⁻³
inches of water (at 4°C)	inches of mercury	0.07355
inches of water (at 4°C)	kgs/sq cm	2.540 x 10 ⁻³
inches of water (at 4°C)	Ounces/sq in	0.5781
inches of water (at 4°C)	pounds/sq ft	5.204
inches of water (at 4°C)	pounds/sq in	0.03613
joules	BTU	9.480 x 10 ⁻⁴
joules	ergs	10 ⁷
joules	foot-pounds	0.7376
joules	watt-hrs	2.778 X 10 ⁻⁴
joules/cm	grams	1.020 x 10 ⁴
joules/cm	dynes	10 ⁷
joules/cm	joules/meters (newtons)	100.0
joules/cm	poundals	723.3
joules/cm	pounds	22.48
kilograms	dynes	980,665.0
kilograms	grams	1,000.0
kilograms	joules/cm	0.09807
kilograms	joules/meter (newtons)	9.807
kilograms	poundals	70.93
kilograms	pounds	2.205
kilograms	tons (long)	9.842 x 10 ⁻⁴
kilograms	tons (short)	1.102 x 10 ⁻³
kilograms/cu meter	grams/cu cm	0.001



Conversions

Change	To	Multiply by
kilograms/cu meter	pounds/cu ft	0.06243
kilograms/cu meter	pounds/cu in	3.613×10^{-5}
kilograms/cu meter	pounds/mil-foot	3.405×10^{-10}
kilograms/meter	pounds/ft	0.6720
kilograms/sq cm	dynes	980,665.0
kilograms/sq cm	atmospheres	0.9678
kilograms/sq cm	feet of water	32.81
kilograms/sq cm	Inches of mercury	28.96
kilograms/sq cm	pounds/sq ft	2,048.0
kilograms/sq cm	pounds/sq in	14.22
kilograms/sq meter	atmospheres	9.678×10^{-5}
kilograms/sq meter	bars	98.07×10^{-6}
kilograms/sq meter	feet of water	3.281×10^{-3}
kilograms/sq meter	Inches of mercury	2.896×10^{-3}
kilograms/sq meter	pounds/sq ft	0.2048
kilograms/sq meter	pounds/sq in	1.422×10^{-3}
kilograms/sq mm	kgs/sq meter	10^{-6}
kilowatts	BTU/min	56.92
kilowatts	foot-lbs/min	4.426×10^4
kilowatts	foot-lbs/sec	737.6
kilowatts	horsepower	1.341
kilowatts	watts	1,000.0
kilowatt-hrs	BTU	3,413.0
kilowatt-hrs	ergs	3.600×10^{13}
kilowatt-hrs	foot-lbs	2.655×10^6
kilowatt-hrs	joules	3.6×10^6
liters	cu cm	1,000.0
liters	cu feet	0.03531
liters	cu inches	61.02
liters	cu meters	0.001
liters	gallons (U.S. liq)	0.2642
long tons	pounds	2,240.0
meters	centimeters	100.0
meters	feet	3.281
meters	inches	39.37
meters	millimeters	1,000.0
miles (statute)	feet	5,280.0
miles (statute)	meters	1,609.0
millimeters	centimeters	0.1
millimeters	feet	3.281×10^{-3}
millimeters	inches	0.03937
mils	inches	0.001
newtons	dynes	10^5
ounces	grams	28.349527
ounces	pounds	0.0625
ounces	ounces (troy)	0.9115
Poise	gram/cm sec	1.0
pounds (avoirdupois)	ounces (troy)	14.5833
poundals	dynes	13,826.0
poundals	joules/cm	1.383×10^{-3}
poundals	joules/meter (newtons)	0.1383
poundals	kilograms	0.01410
poundals	pounds	0.03108
pounds	dynes	44.4823×10^4
pounds	grams	453.5924
pounds	joules/cm	0.04448
pounds	joules/meter (newtons)	4.448
pounds	kilograms	0.4536

Change	To	Multiply by
pounds	ounces	16.0
pounds	ounces (troy)	14.5833
pounds	poundals	32.17
pounds	pounds (troy)	1.21528
pounds	tons (short)	0.0005
pounds of water	cu feet	0.01602
pounds of water	cu inches	27.68
pounds of water	gallons	0.1198
pounds-feet	cm-dynes	1.356×10^7
pounds-feet	cm-grams	13,825.0
pounds-feet	meter-kgs	0.1383
pounds/ft	kgs/meter	1,488
pounds/in	gms/cm	178.6
pounds/sq ft	atmospheres	4.725×10^{-4}
pounds/sq ft	feet of water	0.01602
pounds/sq ft	inches of mercury	0.01414
pounds/sq ft	kgs/sq meter	4,882
pounds/sq ft	pounds/sq in	6.944×10^{-3}
Pounds/sq in	atmospheres	0.06804
Pounds/sq in	inches of water	27.68
Pounds/sq in	feet of water	2.307
Pounds/sq in	inches of mercury	2.036
Pounds/sq in	kgs/sq meter	703.1
Pounds/sq in	pounds/sq ft	144.0
short tons	pounds	2,000.0
short tons	long tons	0.89285
slug	kilogram	14.59
slug	pounds	32.17
square centimeters	sq feet	1.076×10^{-3}
square centimeters	sq inches	0.1550
square centimeters	sq meters	0.0001
square centimeters	sq millimeters	100.0
square feet	sq cms	929.0
square feet	sq inches	144.0
square feet	sq meters	0.09290
square feet	sq millimeters	9.290×10^4
square inches	sq cms	6.452
square inches	sq feet	6.944×10^{-3}
square inches	sq millimeters	645.2
square kilometers	sq cms	10^{10}
square kilometers	sq ft	10.76×10^6
square kilometers	sq inches	1.550×10^9
square kilometers	sq meters	10^6
square meters	sq cms	10^4
square meters	sq feet	10.76
square meters	sq inches	1,550.0
square meters	sq millimeters	10^6
square millimeters	sq cms	0.01
square millimeters	sq feet	1.076×10^{-5}
square millimeters	sq inches	1.550×10^{-3}
tons (long)	kilograms	1,016.0
tons (long)	pounds	2,240.0
tons (long)	tons (short)	1,120
tons (metric)	kilograms	1,000.0
tons (metric)	pounds	2,205.0
watts	BTU/hr	3.4129
watts	BTU/min	0.05688
watts	ergs/sec	10^7
watts	horsepower	1.341×10^{-3}
watts	kilowatts	0.001

“Sweep Loss” Chart

The charts below will assist in developing the “drop” at the intersection of connections and shells or heads.

“Sweep Loss” calculation is based

$$\text{on } R - \sqrt{R^2 - r^2}$$

Where: R = Vessel Radius

and r = Connection Radius

Example #1

Finding the length of an 18" — 150# LWN set thru a 60" ID Shell

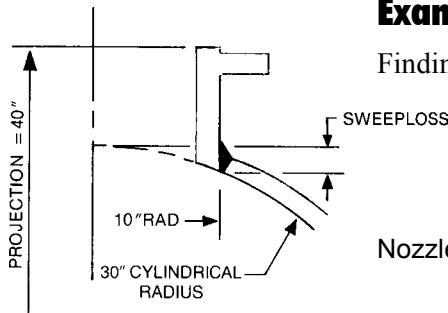

From chart find column with shell radius (30") and then move down to connection radius (10") to find “Sweep Loss” (1.72”).

Nozzle Length = Proj. - Shell Rad. + “Sweep Loss” + Internal Proj.

$$= 40" - 30" + 1.72" + 0 = 11.72"$$

		SHELL RADIUS OR HEAD CROWN RADIUS											
		5.375	6.375	7	8	9	10	1.2	15	18	21	24	27
CONNECTION RADIUS	2	0.39	0.32	0.29	0.25	0.23	0.20	0.17	0.13	0.11	0.10	0.08	0.07
	3	0.92	0.75	0.68	0.58	0.51	0.46	0.38	0.30	0.25	0.22	0.19	0.17
	4	1.78	1.41	1.26	1.07	0.94	0.83	0.69	0.54	0.45	0.38	0.34	0.30
	5	3.40	2.42	2.10	1.76	1.52	1.34	1.09	0.86	0.71	0.60	0.53	0.47
	6	-	4.22	3.39	2.71	2.29	2.00	1.61	1.25	1.03	0.88	0.76	0.68
	7	-	-	7.00	4.13	3.34	2.86	2.25	1.73	1.42	1.20	1.04	0.92
	8	-	-	-	8.00	4.88	4.00	3.06	2.31	1.88	1.58	1.37	1.21
	9	-	-	-	-	9.00	5.64	4.06	3.00	2.41	2.03	1.75	1.54
	10	-	-	-	-	-	10.00	5.37	3.82	3.03	2.53	2.18	1.92
	11	-	-	-	-	-	-	7.20	4.80	3.75	3.11	2.67	2.34
	12	-	-	-	-	-	-	-	12.00	6.00	4.58	3.77	3.22
	13	-	-	-	-	-	-	-	-	7.52	5.55	4.51	3.83
	14	-	-	-	-	-	-	-	-	9.61	6.69	5.35	4.51
	15	-	-	-	-	-	-	-	-	15.00	8.05	6.30	5.27
	16	-	-	-	-	-	-	-	-	-	9.75	7.40	6.11
	17	-	-	-	-	-	-	-	-	-	12.08	8.67	7.06
	18	-	-	-	-	-	-	-	-	-	18.00	10.18	8.13
	19	-	-	-	-	-	-	-	-	-	-	12.06	9.34
	20	-	-	-	-	-	-	-	-	-	-	14.60	10.73
	21	-	-	-	-	-	-	-	-	-	-	21.00	12.38



Example #2

Finding the total thickness of an 18" — 300# studding outlet set thru a 48" OD ASME F&D head with 42" DISH Radius. *Maintaining minimum thickness is priority.* Minimum thickness for this example will be established as 3.25 inches.

From chart find column with head crown radius (42") and move down to bore radius (9") to find "Sweep Loss" #1 (0.98"). Then move down to connection radius (14") to find "Sweep Loss" #2 (2.40").

$$\text{Thickness} = \text{Min. Req'd Thk} + \text{"Sweep Loss" \#2} - \text{"Sweep Loss" \#1}$$

$$= 3.25" + 2.40" - 0.98" = 4.67"$$

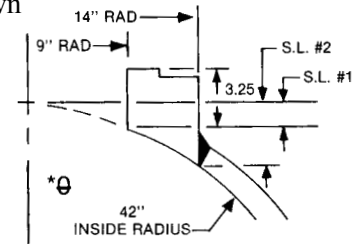

Example #3

Finding the total thickness of an 18" — 300# studding outlet set through a 48" OD ASME F&D head. *Projection is priority.*

From chart find column with head crown radius (42") and move down to connection radius (14") to find "Sweep Loss" (2.40").

$$\text{Thickness} = \text{Proj.} - \text{Inside Depth of Head} + \text{"Sweep Loss"}$$

$$= 12" - 8" + 2.40" = 6.40"$$

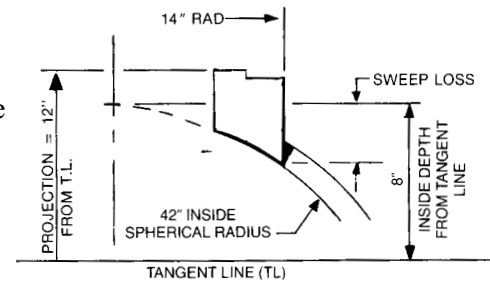

		SHELL RADIUS OR HEAD CROWN RADIUS												
		30	33	36	39	42	45	48	54	60	66	72	78	84
CONNECTION RADIUS	2	0.07	0.06	0.06	0.05	0.05	0.04	0.04	0.04	0.03	0.03	0.03	0.03	0.02
	3	0.15	0.14	0.13	0.12	0.11	0.10	0.09	0.08	0.08	0.07	0.06	0.06	0.05
	4	0.27	0.24	0.22	0.21	0.19	0.18	0.17	0.15	0.13	0.12	0.11	0.10	0.10
	5	0.42	0.38	0.35	0.32	0.30	0.28	0.26	0.23	0.21	0.19	0.17	0.16	0.15
	6	0.61	0.55	0.50	0.46	0.43	0.40	0.38	0.33	0.30	0.27	0.25	0.23	0.21
	7	0.83	0.75	0.69	0.63	0.59	0.55	0.51	0.46	0.41	0.37	0.34	0.31	0.29
	8	1.09	0.98	0.90	0.83	0.77	0.72	0.67	0.60	0.54	0.49	0.45	0.41	0.38
	9	1.38	1.25	1.14	1.05	0.98	0.91	0.85	0.76	0.68	0.62	0.56	0.52	0.48
	10	1.72	1.55	1.42	1.30	1.21	1.13	1.05	0.93	0.84	0.76	0.70	0.64	0.60
	11	2.09	1.89	1.72	1.58	1.47	1.37	1.28	1.13	1.02	0.92	0.85	0.78	0.72
	12	2.50	2.26	2.06	1.89	1.75	1.63	1.52	1.35	1.21	1.10	1.01	0.93	0.86
	13	2.96	2.67	2.43	2.23	2.06	1.92	1.79	1.59	1.43	1.29	1.18	1.09	1.01
	14	3.47	3.12	2.83	2.60	2.40	2.23	2.09	1.85	1.66	1.50	1.37	1.27	1.17
	15	4.02	3.61	3.27	3.00	2.77	2.57	2.40	2.13	1.91	1.73	1.58	1.46	1.35
	16	4.62	4.14	3.75	3.43	3.17	2.94	2.75	2.42	2.17	1.97	1.80	1.66	1.54
	17	5.28	4.72	4.27	3.90	3.59	3.33	3.11	2.75	2.46	2.23	2.04	1.88	1.74
	18	6.00	5.34	4.82	4.40	4.05	3.76	3.50	3.09	2.76	2.50	2.29	2.11	1.95
	19	6.78	6.02	5.42	4.94	4.54	4.21	3.92	3.45	3.09	2.79	2.55	2.35	2.18
	20	7.64	6.75	6.07	5.52	5.07	4.69	4.37	3.84	3.43	3.10	2.83	2.61	2.42
	21	8.58	7.54	6.76	6.14	5.63	5.20	4.84	4.25	3.80	3.43	3.13	2.88	2.67



Conversion Table Inch Fractions to Decimals and Millimeters

Inches		MM	Inches		MM
Fraction	Decimal		Fraction	Decimal	
1/64	0.0156	0.397			
1/32	0.0313	0.794			
	0.0394	1.000	33/64	0.5156	13.097
3/64	0.0469	1.191	17/32	0.5313	13.494
1/16	0.0625	1.588	35/64	0.5469	13.891
5/64	0.0781	1.984		0.5512	14.000
	0.0787	2.000	9/16	0.5625	14.288
3/32	0.0938	2.381	37/64	0.5781	14.684
7/64	0.1094	2.778		0.5906	15.000
	0.1181	3.000	19/32	0.5938	15.081
1/8	0.1250	3.175	39/64	0.6094	15.478
9/64	0.1406	3.572	5/8	0.6250	15.875
5/32	0.1563	3.969		0.6299	16.000
	0.1575	4.000	41/64	0.6406	16.272
11/64	0.1719	4.366	21/32	0.6563	16.669
3/16	0.1875	4.763		0.6693	17.000
	0.1969	5.000	43/64	0.6719	17.066
13/64	0.2031	5.159	11/16	0.6875	17.463
7/32	0.2188	5.556	45/64	0.7031	17.859
15/64	0.2344	5.953		0.7087	18.000
	0.2362	6.000	23/32	0.7188	18.256
1/4	0.2500	6.350	47/64	0.7344	18.653
17/64	0.2656	6.747		0.7480	19.000
	0.2756	7.000	3/4	0.7500	19.050
9/32	0.2813	7.144	49/64	0.7656	19.447
19/64	0.2969	7.541	25/32	0.7813	19.844
5/16	0.3125	7.938		0.7874	20.000
	0.3150	8.000	51/64	0.7969	20.241
21/64	0.3281	8.334	13/16	0.8125	20.638
11/32	0.3438	8.731		0.8268	21.000
	0.3543	9.000	53/64	0.8281	21.034
23/64	0.3594	9.128	27/32	0.8438	21.431
3/8	0.3750	9.525	55/64	0.8594	21.828
25/64	0.3906	9.922		0.8661	22.000
	0.3937	10.000	7/8	0.8750	22.225
13/32	0.4063	10.319	57/64	0.8906	22.622
27/64	0.4219	10.716		0.9055	23.000
	0.4331	11.000	29/32	0.9063	23.019
7/16	0.4375	11.113	59/64	0.9219	23.416
29/64	0.4531	11.509	15/16	0.9375	23.813
15/32	0.4688	11.906		0.9449	24.000
	0.4724	12.000	61/64	0.9531	24.209
31/64	0.4844	12.303	31/32	0.9688	24.606
1/2	0.5000	12.700		0.9843	25.000
			1	1.0000	25.400



Weight of Circular Steel Plates per 1" of Thickness

Dia. Inches	Weight per Inch Thickness	Dia. Inches	Weight per Inch Thickness	Dia. Inches	Weight per Inch Thickness	Dia. Inches	Weight per Inch Thickness	Dia. Inches	Weight per Inch Thickness	Dia. Inches	Weight per Inch Thickness	Dia. Inches	Weight per Inch Thickness
1	0.22	9	18.02	17	64.30	25	139.07	33	242.31	41	374.04	49	534.29
1 1/8	0.28	9 1/8	18.53	17 1/8	65.25	25 1/8	140.46	33 1/8	244.15	41 1/8	376.32	49 1/8	537.02
1 1/4	0.35	9 1/4	19.04	17 1/4	66.21	25 1/4	141.86	33 1/4	246.00	41 1/4	378.61	49 1/4	539.76
1 3/8	0.42	9 3/8	19.56	17 3/8	67.17	25 3/8	143.27	33 3/8	247.85	41 3/8	380.91	49 3/8	542.50
1 1/2	0.50	9 1/2	20.08	17 1/2	68.14	25 1/2	144.69	33 1/2	249.71	41 1/2	383.22	49 1/2	545.25
1 5/8	0.59	9 5/8	20.61	17 5/8	69.12	25 5/8	146.11	33 5/8	251.58	41 5/8	385.53	49 5/8	548.01
1 3/4	0.68	9 3/4	21.15	17 3/4	70.10	25 3/4	147.54	33 3/4	253.45	41 3/4	387.85	49 3/4	550.78
1 7/8	0.78	9 7/8	21.70	17 7/8	71.09	25 7/8	148.97	33 7/8	255.33	41 7/8	390.17	49 7/8	553.55
2	0.89	10	22.25	18	72.09	26	150.42	34	257.22	42	392.51	50	556.33
2 1/8	1.00	10 1/8	22.81	18 1/8	73.09	26 1/8	151.87	34 1/8	259.12	42 1/8	394.85	50 1/8	559.11
2 1/4	1.13	10 1/4	23.38	18 1/4	74.11	26 1/4	153.32	34 1/4	261.02	42 1/4	397.19	50 1/4	561.90
2 3/8	1.26	10 3/8	23.95	18 3/8	75.13	26 3/8	154.79	34 3/8	262.93	42 3/8	399.55	50 3/8	564.70
2 1/2	1.39	10 1/2	24.53	18 1/2	76.15	26 1/2	156.26	34 1/2	264.84	42 1/2	401.91	50 1/2	567.51
2 5/8	1.53	10 5/8	25.12	18 5/8	77.18	26 5/8	157.74	34 5/8	266.77	42 5/8	404.28	50 5/8	570.32
2 3/4	1.68	10 3/4	25.71	18 3/4	78.22	26 3/4	159.22	34 3/4	268.69	42 3/4	406.65	50 3/4	573.14
2 7/8	1.84	10 7/8	26.31	18 7/8	79.27	26 7/8	160.71	34 7/8	270.63	42 7/8	409.03	50 7/8	575.97
3	2.00	11	26.92	19	80.32	27	162.21	35	272.57	43	411.42	51	578.80
3 1/8	2.17	11 1/8	27.54	19 1/8	81.38	27 1/8	163.72	35 1/8	274.53	43 1/8	413.82	51 1/8	581.64
3 1/4	2.36	11 1/4	28.16	19 1/4	82.45	27 1/4	165.23	35 1/4	276.48	43 1/4	416.22	51 1/4	584.49
3 3/8	2.54	11 3/8	28.79	19 3/8	83.52	27 3/8	166.75	35 3/8	278.45	43 3/8	418.63	51 3/8	587.34
3 1/2	2.73	11 1/2	29.43	19 1/2	84.61	27 1/2	168.27	35 1/2	280.42	43 1/2	421.04	51 1/2	590.21
3 5/8	2.93	11 5/8	30.07	19 5/8	85.69	27 5/8	169.81	35 5/8	282.40	43 5/8	423.47	51 5/8	593.07
3 3/4	3.14	11 3/4	30.72	19 3/4	86.79	27 3/4	171.35	35 3/4	284.38	43 3/4	425.90	51 3/4	595.95
3 7/8	3.35	11 7/8	31.38	19 7/8	87.89	27 7/8	172.89	35 7/8	286.37	43 7/8	428.34	51 7/8	598.83
4	3.56	12	32.04	20	89.00	28	174.45	36	288.37	44	430.78	52	601.72
4 1/8	3.79	12 1/8	32.71	20 1/8	90.12	28 1/8	176.01	36 1/8	290.38	44 1/8	433.23	52 1/8	604.62
4 1/4	4.02	12 1/4	33.39	20 1/4	91.24	28 1/4	177.58	36 1/4	292.39	44 1/4	435.69	52 1/4	607.52
4 3/8	4.26	12 3/8	34.07	20 3/8	92.37	28 3/8	179.15	36 3/8	294.41	44 3/8	438.15	52 3/8	610.43
4 1/2	4.51	12 1/2	34.77	20 1/2	93.51	28 1/2	180.73	36 1/2	296.44	44 1/2	440.63	52 1/2	613.35
4 5/8	4.76	12 5/8	35.46	20 5/8	94.65	28 5/8	182.32	36 5/8	298.47	44 5/8	443.10	52 5/8	616.27
4 3/4	5.02	12 3/4	36.17	20 3/4	95.80	28 3/4	183.92	36 3/4	300.51	44 3/4	445.59	52 3/4	619.20
4 7/8	5.29	12 7/8	36.88	20 7/8	96.96	28 7/8	185.52	36 7/8	302.56	44 7/8	448.08	52 7/8	622.14
5	5.56	13	37.60	21	98.12	29	187.13	37	304.62	45	450.58	53	625.09
5 1/8	5.84	13 1/8	38.33	21 1/8	99.29	29 1/8	188.75	37 1/8	306.68	45 1/8	453.09	53 1/8	628.04
5 1/4	6.13	13 1/4	39.06	21 1/4	100.47	29 1/4	190.37	37 1/4	308.75	45 1/4	455.60	53 1/4	631.00
5 3/8	6.43	13 3/8	39.80	21 3/8	101.66	29 3/8	192.00	37 3/8	310.82	45 3/8	458.12	53 3/8	633.96
5 1/2	6.73	13 1/2	40.55	21 1/2	102.85	29 1/2	193.64	37 1/2	312.90	45 1/2	460.65	53 1/2	636.94
5 5/8	7.04	13 5/8	41.31	21 5/8	104.05	29 5/8	195.28	37 5/8	314.99	45 5/8	463.19	53 5/8	639.92
5 3/4	7.36	13 3/4	42.07	21 3/4	105.26	29 3/4	196.94	37 3/4	317.09	45 3/4	465.73	53 3/4	642.90
5 7/8	7.68	13 7/8	42.83	21 7/8	106.47	29 7/8	198.59	37 7/8	319.19	45 7/8	468.28	53 7/8	645.90
6	8.01	14	43.61	22	107.69	30	200.26	38	321.30	46	470.83	54	648.90
6 1/8	8.35	14 1/8	44.39	22 1/8	108.92	30 1/8	201.93	38 1/8	323.42	46 1/8	473.39	54 1/8	651.91
6 1/4	8.69	14 1/4	45.18	22 1/4	110.15	30 1/4	203.61	38 1/4	325.55	46 1/4	475.96	54 1/4	654.92
6 3/8	9.04	14 3/8	45.98	22 3/8	111.39	30 3/8	205.30	38 3/8	327.68	46 3/8	478.54	54 3/8	657.94
6 1/2	9.40	14 1/2	46.78	22 1/2	112.64	30 1/2	206.99	38 1/2	329.82	46 1/2	481.12	54 1/2	660.97
6 5/8	9.77	14 5/8	47.59	22 5/8	113.90	30 5/8	208.69	38 5/8	331.96	46 5/8	483.71	54 5/8	664.01
6 3/4	10.14	14 3/4	48.41	22 3/4	115.16	30 3/4	210.40	38 3/4	334.11	46 3/4	486.31	54 3/4	667.05
6 7/8	10.52	14 7/8	49.23	22 7/8	116.43	30 7/8	212.11	38 7/8	336.27	46 7/8	488.91	54 7/8	670.10
7	10.90	15	50.06	23	117.70	31	213.83	39	338.44	47	491.52	55	673.15
7 1/8	11.30	15 1/8	50.90	23 1/8	118.99	31 1/8	215.56	39 1/8	340.61	47 1/8	494.14	55 1/8	676.22
7 1/4	11.70	15 1/4	51.75	23 1/4	120.28	31 1/4	217.29	39 1/4	342.79	47 1/4	496.77	55 1/4	679.29
7 3/8	12.10	15 3/8	52.60	23 3/8	121.57	31 3/8	219.04	39 3/8	344.98	47 3/8	499.40	55 3/8	682.36
7 1/2	12.52	15 1/2	53.46	23 1/2	122.88	31 1/2	220.79	39 1/2	347.17	47 1/2	502.04	55 1/2	685.45
7 5/8	12.94	15 5/8	54.32	23 5/8	124.19	31 5/8	222.54	39 5/8	349.37	47 5/8	504.68	55 5/8	688.54
7 3/4	13.36	15 3/4	55.19	23 3/4	125.50	31 3/4	224.30	39 3/4	351.58	47 3/4	507.34	55 3/4	691.64
7 7/8	13.80	15 7/8	56.07	23 7/8	126.83	31 7/8	226.07	39 7/8	353.79	47 7/8	510.00	55 7/8	694.74
8	14.24	16	56.96	24	128.16	32	227.85	40	356.02	48	512.66	56	697.85
8 1/8	14.69	16 1/8	57.85	24 1/8	129.50	32 1/8	229.63	40 1/8	358.24	48 1/8	515.34	56 1/8	700.97
8 1/4	15.14	16 1/4	58.75	24 1/4	130.84	32 1/4	231.42	40 1/4	360.48	48 1/4	518.02	56 1/4	704.10
8 3/8	15.61	16 3/8	59.66	24 3/8	132.20	32 3/8	233.22	40 3/8	362.72	48 3/8	520.70	56 3/8	707.23
8 1/2	16.08	16 1/2	60.58	24 1/2	133.56	32 1/2	235.03	40 1/2	364.97	48 1/2	523.40	56 1/2	710.37
8 5/8	16.55	16 5/8	61.50	24 5/8	134.92	32 5/8	236.84	40 5/8	367.23	48 5/8	526.10	56 5/8	713.52
8 3/4	17.04	16 3/4	62.43	24 3/4	136.30	32 3/4	238.66	40 3/4	369.49	48 3/4	528.81	56 3/4	716.67
8 7/8	17.53	16 7/8	63.36	24 7/8	137.68	32 7/8	240.48	40 7/8	371.76	48 7/8	531.52	56 7/8	719.83



FVC Terms and Warranty

1. Any Sales Tax, Manufacturer's Tax, or Use tax imposed by Federal, State or Municipal Law is to be added to the prices and assumed by purchaser.
2. Seller is not responsible for delays, defaults, or damages occasioned by any causes beyond seller's control including, without limitation, governmental actions or orders, embargoes, strikes, fires and floods. In any event, partial deliveries shall be permitted at seller's option.
3. Cancellations, of orders placed with and accepted by us, can be made only with our written consent. Upon request to cancel, we will advise amount of cancellation charges, in addition to charges for dies, work in process, products produced, including machine work, etc., and all liability for raw materials. Should you change your material specification for your order after we have ordered or received the material, you are to assume all liability for the material covered by your initial specification.
4. It is understood that dies, tools, and patterns required to produce the article quoted on shall remain the property of FVC, Inc. Preparation charges or charges for dies, tools, and patterns represents only a portion of cost. Payment of such charge does not give you any right, title, or interest in such dies, tools, or other products of preparation.
5. Purchaser represents that purchaser is solvent and can and will pay for products delivered to purchaser in accordance with the terms hereof. However, seller retains the right to require full payment in advance if in seller's sole discretion the financial position of the purchaser so requires.
6. THERE ARE NO WARRANTIES WHICH EXTEND BEYOND THE DESCRIPTION ON THE FACE HEREOF EXCEPTING ONLY THAT EACH PRODUCT SOLD HEREUNDER IS WARRANTED TO BE FREE FROM MANUFACTURING DEFECTS, AND IF DEFECTIVE, WILL EITHER BE REPAIRED OR REPLACED WITHOUT CHARGE OR THE PURCHASE PRICE WILL BE REFUNDED, AT THE OPTION OF SELLER. SELLER MAKES NO OTHER WARRANTY, EITHER EXPRESS OR IMPLIED. SELLER'S LIABILITY IS LIMITED TO THE SALE PRICE OF THE PARTICULAR PRODUCT. IN NO EVENT SHALL SELLER BE LIABLE FOR ANY CONSEQUENTIAL DAMAGES OR FOR EXPENSE OCCASIONED BY THE USE OF DEFECTIVE PRODUCTS. SELLER'S LIABILITIES AS ABOVE SET OUT SHALL NOT BE EXTENDED BECAUSE OF ADVICE GIVEN BY SELLER IN CONNECTION WITH THE DESIGN, INSTALLATION OR USE OF ANY PRODUCT. PURCHASER AGREES THAT IF THE PRODUCTS SOLD HEREUNDER ARE BY PURCHASER RE-SOLD, PURCHASER WILL INCLUDE IN THE CONTRACT FOR RE-SALE, PROVISIONS WHICH LIMIT RECOVERIES AGAINST THIS SELLER IN ACCORDANCE WITH THIS PARAGRAPH.
7. Claims for shortages must be filed within ten days of receipt of shipment.
8. We assume no responsibility if the manufacture and sale to you of the items specified by you is an infringement of patent rights of other persons, you assume responsibility for and will protect us from such infringement liability, except as to our own manufacturing equipment and processes.
9. Stenographic or clerical errors are subject to correction.
10. Deferred deliveries are subject to FVC, Inc. written approval.
11. Purchases from us may not be returned without our written consent.
12. These terms and conditions shall control in any contract resulting from or arising out of this quotation, price sheet, or acknowledgement, regardless of printed terms, conditions or provisions found in responses hereto or documents giving rise hereto, all of such printed matters incorporated there in being deemed waived insofar as the same differ from these terms and conditions, unless such differing terms, conditions or provisions shall be specifically asserted for inclusion in written form other than printing and be specifically accepted by seller as a change in these terms and conditions by express reference in writing. The applicability of this paragraph is an express condition to any contract being formed between us.
13. Catalog product presentations including catalog dimensions, designs and specifications are representative of product availability at time of publication only. Actual geometry dimensions and designs are subject to designs and manufacturing changes without notice.
14. Material quoted as being available from stock is normally available for immediate shipment but subject to prior sale.
15. The above and foregoing terms and conditions are the final expressions of the terms and conditions of the contract which may be or is formed between us and they are intended also as a complete and exhaustive statement of the terms and conditions of such agreement.
16. All published prices are/or may be subject to a surcharge to customers, who, by reason of current or prior trade or business practices or course of dealings with FVC have increased or may increase marketing or distribution costs.